

SUSMP Case Study #3

City of Los Angeles, Fire Facilities Bond Program

Allan T. Kawaguchi, P.E.

Fire Facilities Bond Program Manager

Los Angeles Bureau of Engineering

**City of Los Angeles
SUSMP Developers/
Planners Conference
November 5, 2003**

Co-Authors

Christine Salvaggio, P.E.

Project Manager, Fire Facilities Bond Program

Battalion Chief John Duca

Los Angeles Fire Department

Fire Bond Program

 Proposition F approved in November 2000

 \$378.5 million to repair, replace, and/or expand fire facilities

 Bureau of Engineering teamed with LAFD

 2 expansions

 9 standard fire stations

 6 regional fire stations

 1 recruit training facility

 1 satellite station

 Van Nuys Air Operations

 Special Fire Facilities

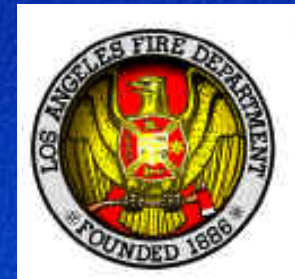

New Fire Facilities

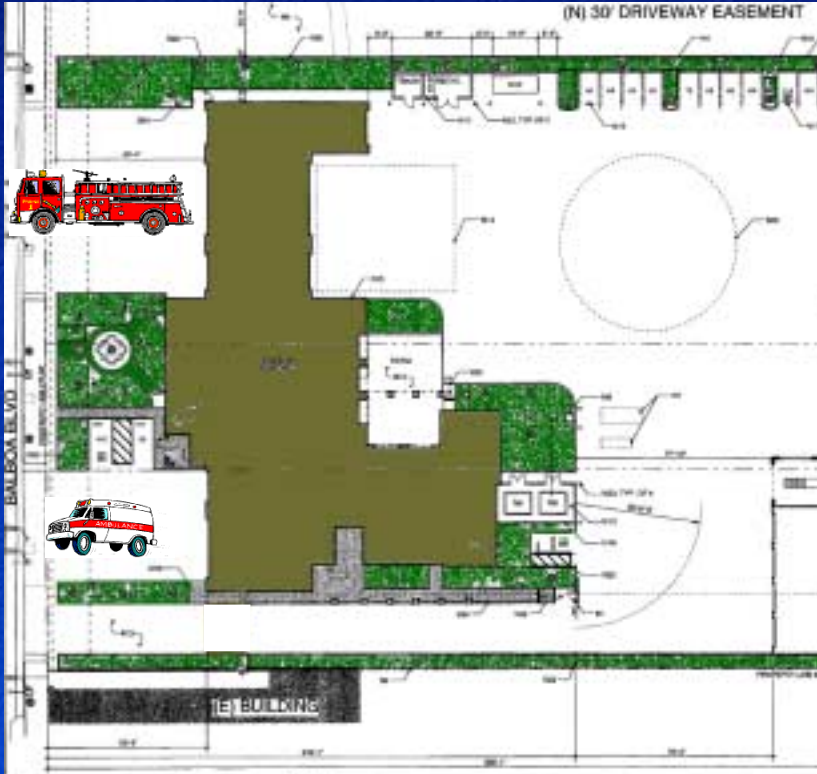

Site Plan for Typical Mid-Block Fire Station



Standard



Approx. 1 acre site



Trucks and Engines
Drive-Thru



Ambulance Reverse-In



Regional



Standard Plus



Approx. 2 acre site



Large Training Yard



Covered Maintenance Pit



Recruit Training Center



Regional Plus



Drill Tower



Live Fire Simulations

Stormwater Post-Construction BMPs

“Prop F” Fire Stations fall into one or more of these three new development categories requiring post-construction BMPs:

- **Site Specific Activities**
 - **Vehicle or Equipment Fueling**
 - **Vehicle or Equipment Washing**
- **25 or more parking spaces**
- **>1 acre Impervious Surface**

Site Specific BMPs

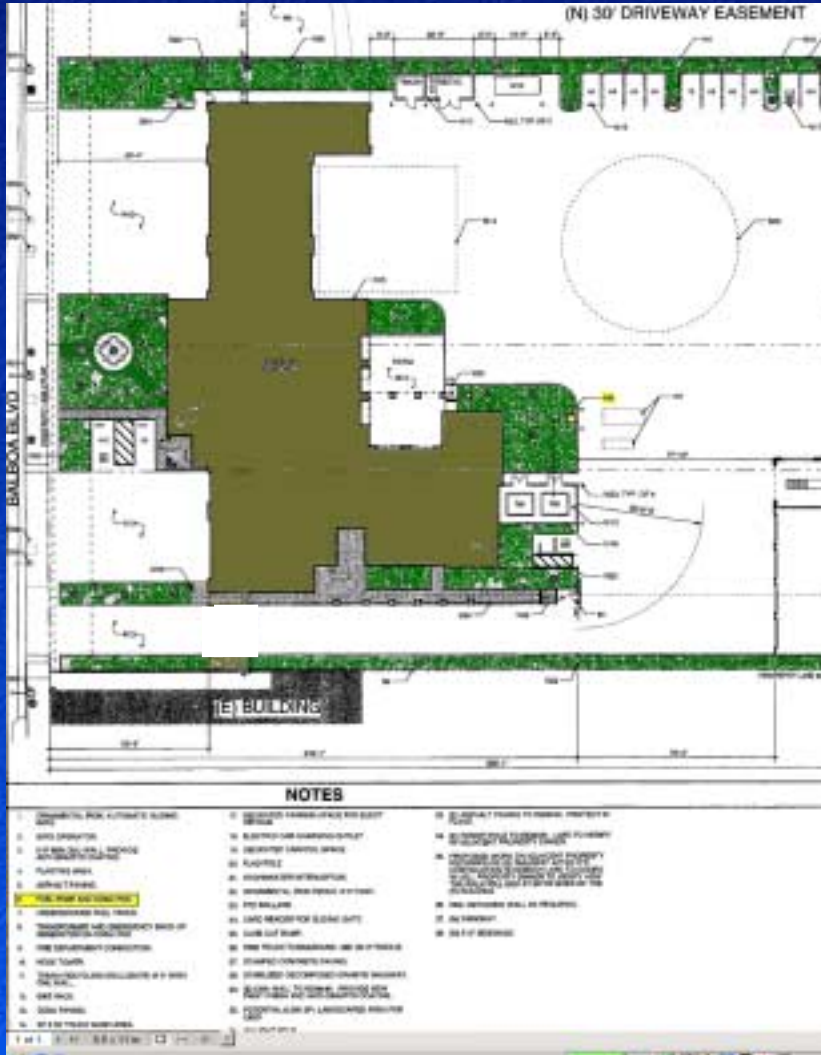

Fuel Pump

- Good Housekeeping Measures
- Vegetated Areas
- Elevated Concrete Pad

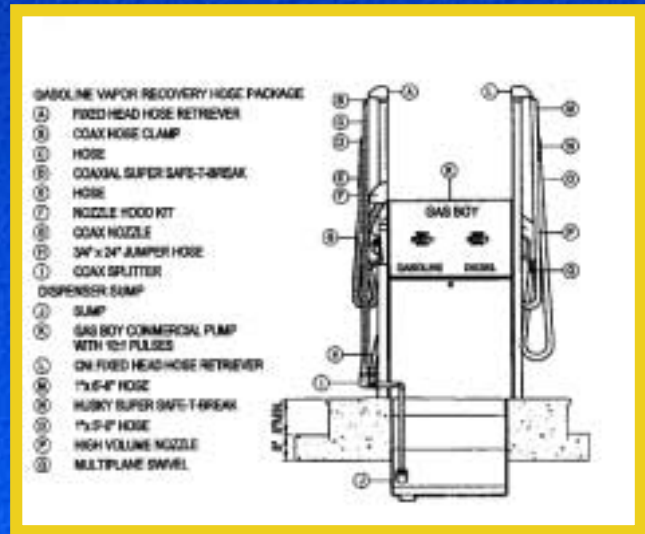

Site Specific BMPs

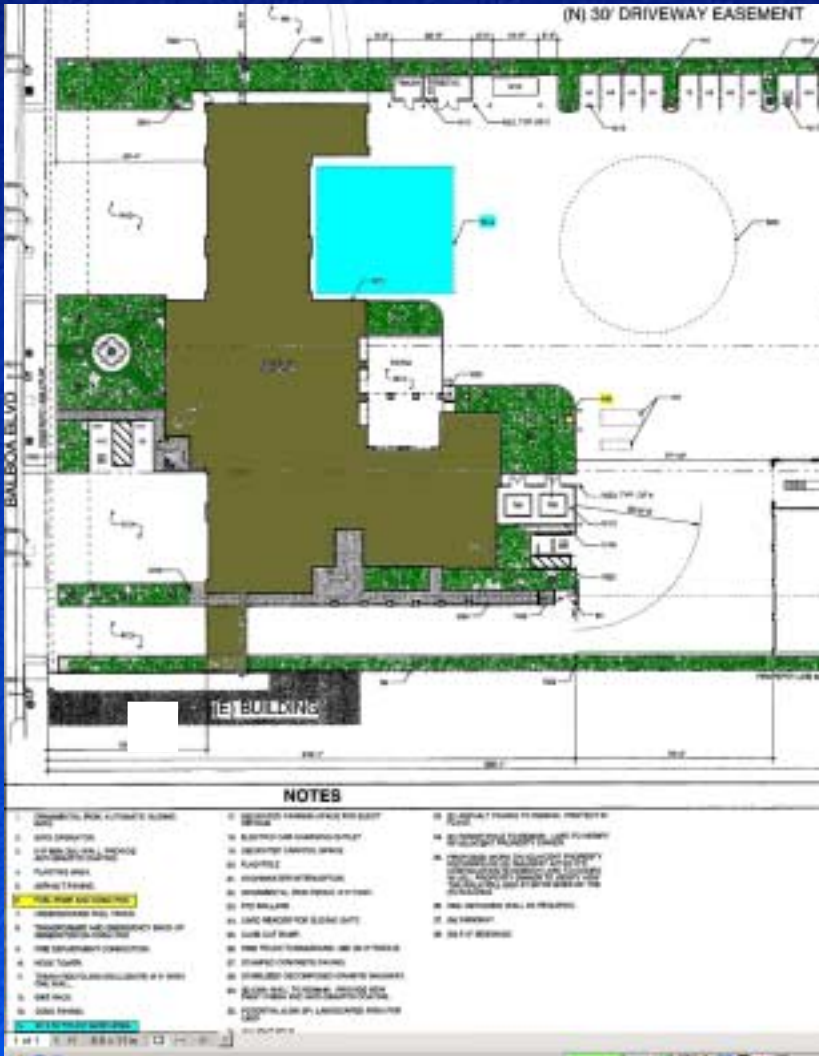

Truck Wash

- Designated Area
- Drains to Clarifier
- Rain Water Diverter Switch with Signage

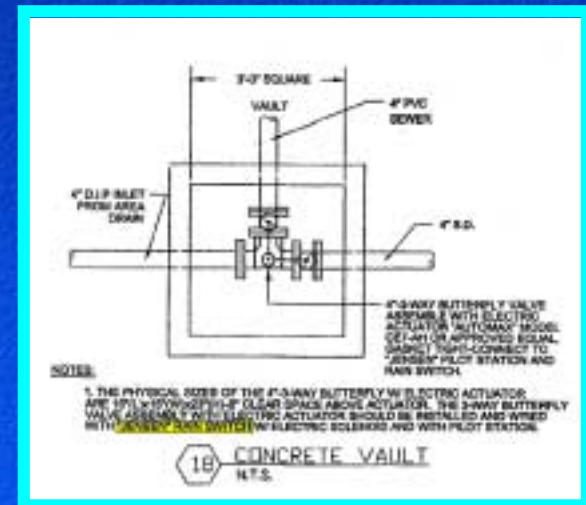

Parking Area BMPs

- Stenciling
- Catch Basin Inserts
- Trench Drain Inserts

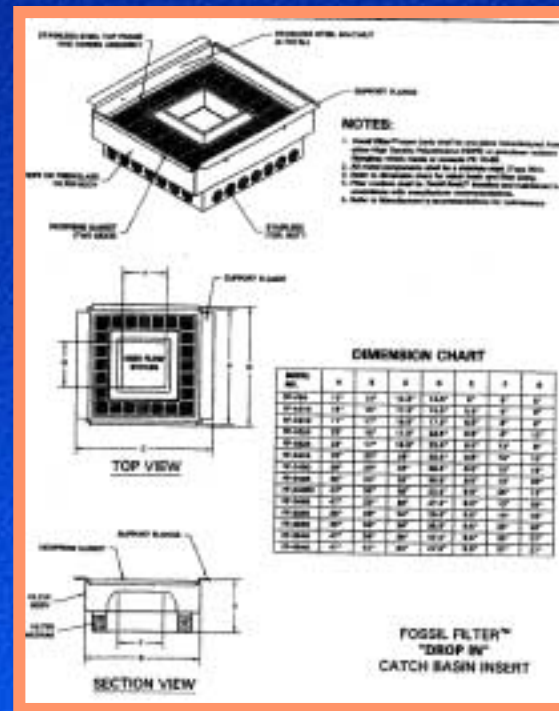
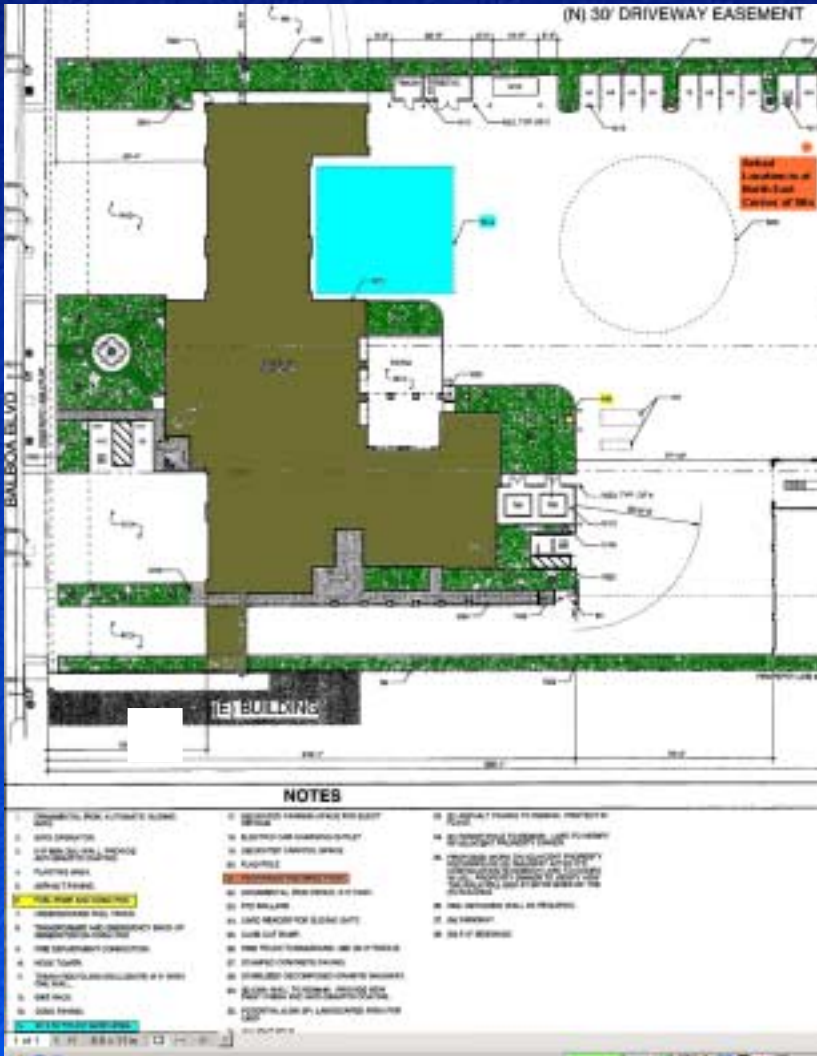

Impervious Surface BMPs

Stormwater Interceptor Detention and Treatment

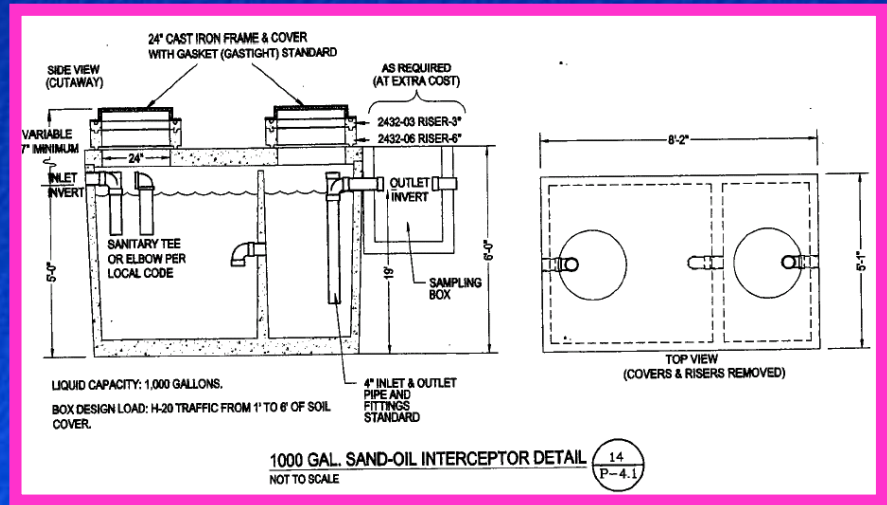
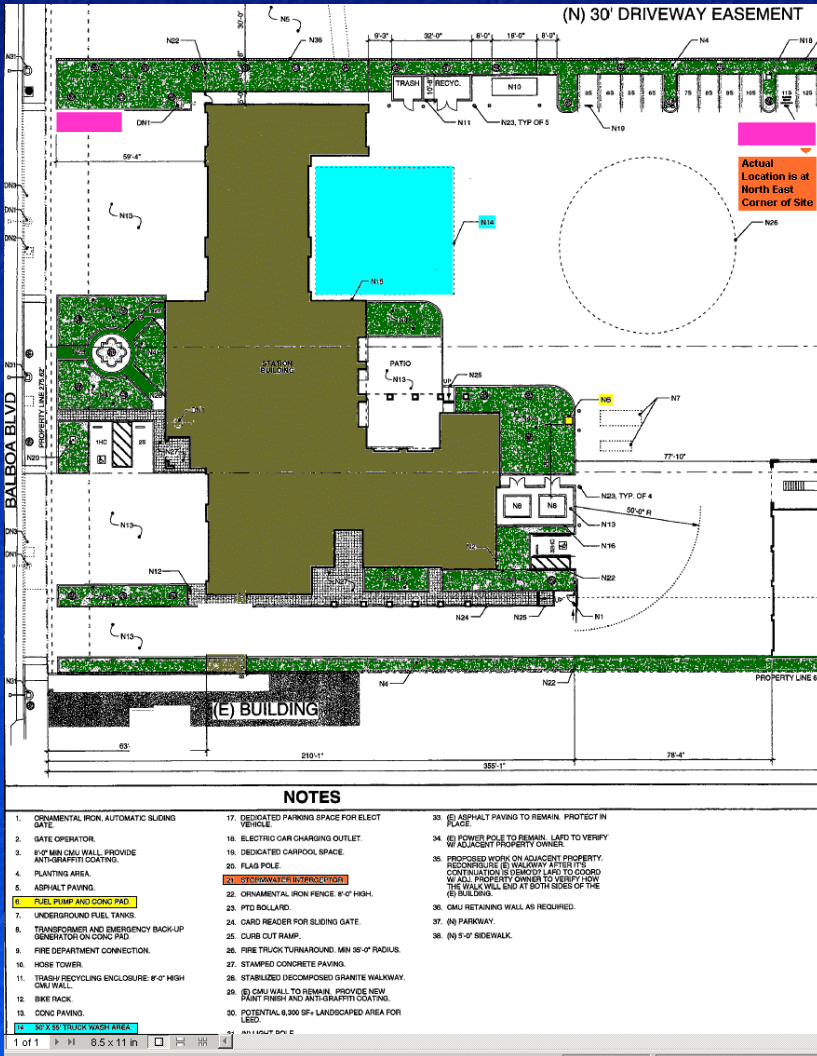

Special BMPs

- **Infiltration Devices**
 - Detention Basin
 - Dry Well

- **Recycled Water**

Related Post-Development Practices

- **Leadership in Energy and Environmental Design (LEED)**
 - **All Prop F designed for Certified Level**
 - **Some pursuing Sustainable Site Credit 6 “Stormwater Management”**
 - **Some pursuing Water Efficiency Credit 1 by using reclaimed wastewater**