

Summary Report: Evaluation of Alternative Solid Waste Processing Technologies

Prepared for:

City of Los Angeles
Department of Public Works
Bureau of Sanitation
419 S. Spring Street, Suite 900
Los Angeles, CA 90013



Prepared by:

URS Corporation
915 Wilshire Boulevard, Suite 700
Los Angeles, CA 90017

September 2005

To Protect Public Health
and the Environment



TABLE OF CONTENTS

<u>Section</u>	<u>Page</u>
1.0 INTRODUCTION	1
1.1 Thermal Technologies	1
1.2 Biological/Chemical Technologies.....	2
1.3 Physical Technologies	2
2.0 TECHNOLOGY SCREENING PROCESS	4
3.0 SUPPLIER SCREENING AND SUPPLIER TECHNOLOGY SUMMARY	5
4.0 LIFE CYCLE ANALYSIS	7
4.1 Net Energy Consumption.....	15
4.2 Criteria Pollutants	16
4.3 Carbon Emissions	16
5.0 COMPARATIVE ANALYSIS OF TECHNOLOGIES	17
5.1 Throughput.....	18
5.2 Electricity Production	19
5.3 Diversion Rate	21
5.4 Air Emissions.....	21
5.5 Advanced Thermal Recycling.....	21
5.6 Thermal Conversion.....	22
5.7 Biological Conversion	23
5.8 Regulatory Issues	24
5.9 Advanced Thermal Recycling.....	24
5.10 Thermal Conversion.....	25
5.11 Biological Conversion	25
5.12 Capital Cost.....	25
5.13 Annual Revenues	25
5.14 Breakeven Tipping Fees	27
6.0 RANKING OF TECHNOLOGIES	27
7.0 FINDINGS	29
8.0 CONCLUSIONS	34
9.0 RECOMMENDATIONS	35
9.1 Initiate Public Outreach	36

<u>Section</u>	<u>Page</u>
9.2 Develop a Short List of Suppliers.....	36
9.3 Conduct Initial Siting Study.....	37
9.4 Prepare a Request for Proposal and Select Preferred Suppliers	37
9.5 Conduct Facility Permitting and Conceptual Design.....	37
9.6 Perform Detailed Design and Construction	37

<u>List of Tables</u>	<u>Page</u>
Table 1 List of Alternative MSW Processing Technologies.....	4
Table 2 Technology Supplier Short List	6
Table 3 Thermal Conversion Facilities	8
Table 4 Advanced Thermal Conversion Facilities.....	10
Table 5 Biological Conversion Facilities.....	11
Table 6 Criteria Performance Levels and Ratings	27
Table 7 Key Findings	30
Table 8 Recommended Activities for MSW Processing Facility Development for the City of Los Angeles	35

<u>List of Figures</u>	<u>Page</u>
Figure 1 Anatomy of a Conversion Facility	3
Figure 2 Life Cycle Inputs and Outputs of a Waste Management Process	7
Figure 3 Landfill Scenario Illustration	14
Figure 4 Advanced Thermal Recycling Scenario Illustration	14
Figure 5 Pyrolysis/Gasification Scenario Illustration	15
Figure 6 Waste Conversion (Anaerobic Digestion) Scenario	15
Figure 7 Annual Net Energy Consumption by Scenario	16
Figure 8 Annual Net Pounds of Criteria Air Emissions by Scenario	17
Figure 9 Annual Net Metric Tons of Carbon Equivalent by Scenario	18
Figure 10 Throughput by Supplier (TPY).....	19
Figure 11 Net Electricity Production, MW	20
Figure 12 Energy Efficiency, Net kWh/Ton	20
Figure 13 Diversion Rate, Percent of Throughput	22
Figure 14 Capital Cost, \$/TPY	26
Figure 15 Total Revenue/Ton by Supplier	26
Figure 16 Estimated Breakeven Tipping Fee and Worst Case Breakeven Tipping Fee	28
Figure 17 Total Ranking Score by Supplier	29

1.0 INTRODUCTION

The City of Los Angeles Department of Public Works, Bureau of Sanitation engaged URS Corporation to conduct an evaluation of alternative municipal solid waste (MSW) processing technologies to process residential refuse, or post-source separated MSW. The City uses three “bins” to collect solid waste from residences: green bin (green waste), blue bin (recyclables), and black bin (refuse). The green and blue bin material is recycled. The black bin refuse, or post-source separated MSW, which is landfilled, is the subject of this study. The study began with development of the City’s overall project objectives. The highest-level objective is:

“Identify alternative MSW processing technologies that will increase landfill diversion in an environmentally sound manner, while emphasizing options that are energy efficient, socially acceptable, and economical.”

This objective was subdivided into three lower-level objectives:

- Maximize Environmental (Siting) Feasibility (i.e., minimize impacts to the environment and citizens)
- Maximize Technical Feasibility (i.e., search for technologies that are commercially available within the development timeframe of 2005-2010 and will significantly increase diversion from landfills)
- Maximize Economic Feasibility (i.e., provide an overall cost that is competitive with other solid waste processing methods)

These objectives were applied, through the use of screening criteria, to identify potential technologies that could meet the City’s objectives. Technologies initially identified were:

- Thermal Technologies
- Biological/Chemical Technologies
- Physical Technologies

1.1 Thermal Technologies

Thermal technologies are those technologies that operate at temperatures greater than 400°F and have higher reaction rates. They typically operate in a temperature range of 700°F to 10,000°F. Most thermal technologies are used to produce electricity as a primary byproduct. Thermal technologies include advanced thermal recycling (a state-of-the-art form of waste-to-energy facilities) and thermal conversion (a process that converts the organic carbon-based portion of the MSW waste stream into a synthetic gas which is subsequently used to produce products such as electricity, chemicals, or green fuels).

1.2 Biological/Chemical Technologies

Biological/chemical technologies operate at lower temperatures and lower reaction rates. They can accept feedstock with high moisture levels, but require material that is biodegradable. Some technologies involve the synthesis of products using chemical processing carried out in multiple stages. Byproducts can vary, which include: electricity, compost and chemicals.

1.3 Physical Technologies

Physical technologies involve altering the physical characteristics of the MSW feedstock. These materials in MSW may be separated, shredded, and/or dried in a processing facility. The resulting material is referred to as refuse-derived fuel (RDF). It may be densified or pelletized into homogeneous fuel pellets and transported and combusted as a supplementary fuel in utility boilers.

The solid waste processing technologies evaluated in this study include advanced thermal recycling and a group of technologies commonly referred to as “conversion facilities.”

Advanced thermal recycling is a second generation advancement of technology that utilizes complete combustion of organic carbon-based materials *in an oxygen-rich environment*, typically at temperatures of 1,300°F to 2,500°F, producing an exhaust gas composed primarily of carbon dioxide (CO₂) and water (H₂O) with inorganic materials converted to bottom ash and fly ash. The hot exhaust gases flow through a boiler, where steam is produced for driving a steam turbine-generator, thereby producing electricity. The cooled waste gases flow through an advanced emission control system designed to capture and recover components in the flue gas, converting them to marketable by-products such as gypsum (e.g., for wallboard manufacture) and hydrochloric acid (used for water treatment). The bottom ash and fly ash are segregated, allowing for recovery/recycling of metals from the bottom ash, and use of the bottom ash as a road base and construction material. The advanced recycling and emission control systems with recovery/recycling go beyond the technology utilized at conventional resource recovery plants such as the Commerce Refuse-to-Energy facility and the Southeast Resource Recovery facility.

A conversion facility *typically* consists of the four components shown in the rectangles of Figure 1.

The first component involves pre-processing of the feedstock. The purpose of the pre-processing step is two-fold: to remove any remaining recyclable materials (e.g., glass, metal), and to prepare feedstock for treatment in the conversion unit. All conversion units have specific requirements regarding the composition of the feedstock, such as moisture content, size limitations, and content (e.g., biodegradables versus all other carbon-based material, such as rubber tires or plastics). The pre-processing system must be designed to create an

FIGURE 1
ANATOMY OF A CONVERSION FACILITY

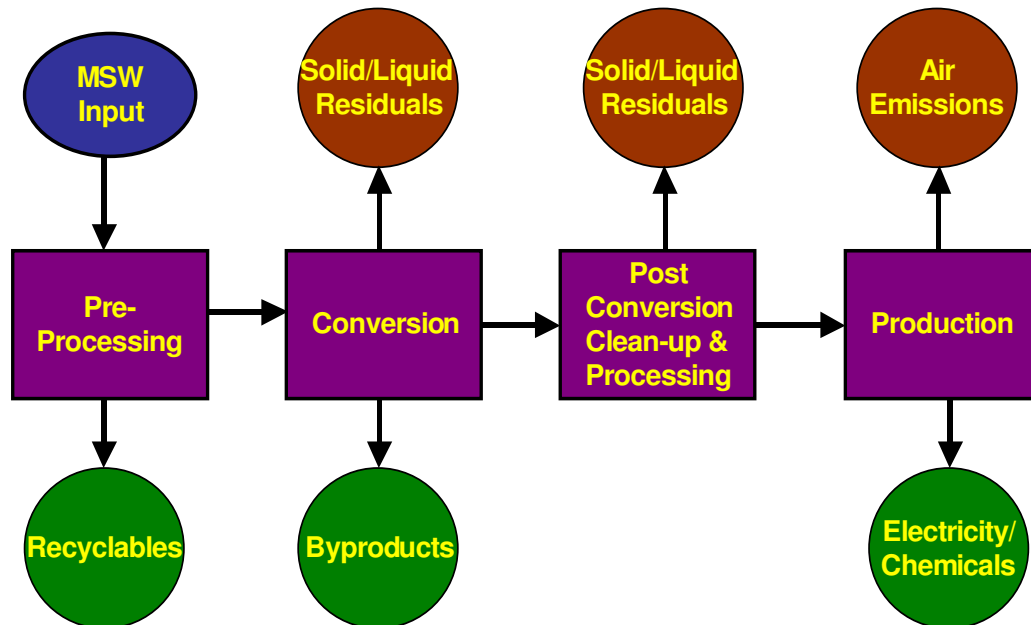

acceptable feedstock for the conversion unit. Pre-processing can be very simple (e.g., primarily sizing) or quite extensive, depending upon the needs of the conversion unit.

The second component is the conversion unit. This unit will process the prepared feedstock and generate certain byproducts, which can usually be marketed. In addition, the conversion unit may produce a small quantity of solid or liquid residuals that could be disposed in a landfill.

Some conversion units will produce an output that requires another processing step before use. For example, if a synthetic fuel gas or biogas is generated, the gas will undergo cleaning and further processing before being used to produce energy in the fourth component. A small quantity of solid or liquid residuals may be created in this step as well. Other conversion systems move from the conversion step directly to the production step.

The final output from the conversion unit is used in a production process. In many cases, a synthetic gas or biogas is input to a power facility that produces electricity for sale into the power grid. This production unit does produce air emissions and sometimes a small quantity of solid residual.

2.0 TECHNOLOGY SCREENING PROCESS

Table 1 shows the sixteen alternative MSW processing technologies that were screened using a set of basic technology capability and experience criteria. Key screening issues were:

- Meet 200 ton/day capacity (throughput) requirement
- Consider technologies at the commercial or late-emerging stage
- Include technologies that can produce marketable byproducts
- Include technologies that are compatible with post-source separated MSW

**TABLE 1
LIST OF ALTERNATIVE MSW PROCESSING TECHNOLOGIES**

Waste Processing Technology Group	Waste Processing Technology
Thermal Technologies	Advanced Thermal Recycling
	Pyrolysis
	Pyrolysis/Gasification
	Pyrolysis/Steam Reforming
	Conventional Gasification-Fluid Bed
	Conventional Gasification-Fixed Bed
	Plasma Arc Gasification
Biological/Chemical Technologies	Anaerobic Digestion
	Aerobic Digestion/Composting
	Ethanol Fermentation
	Syngas-to-Ethanol
	Biodiesel
	Thermal Depolymerization
	Catalytic Cracking
Physical Technologies	Refuse-Derived Fuel (RDF)
	Densification/Pelletization

No environmental or cost/revenue screening criteria were considered because these issues would require more detailed technical data than was available at this point in the study.

Through this process, ten technologies within the technology groups of thermal and biological technologies were identified that meet the following criteria:

- **Waste Treatability:** ability of the alternative MSW processing technology to efficiently treat the organic portion of the black container waste stream
- **Conversion Performance:** ability of the conversion technology to convert the organic portion of the post-source separated MSW stream into useful products
- **Throughput Requirement:** ability of the alternative processing technology to treat at least 200 tons/day of post-source separated MSW in 2008-2010
- **Commercial Status:** conversion technology that can be developed on a commercial scale within the project development period (2008-2010)
- **Technology Capability:** Can support the development of conversion technology at commercial scale and can demonstrate the conversion technology with MSW at a scale of at least 25 tons/day

The remaining ten technologies were brought forward:

1. Advanced Thermal Recycling
2. Pyrolysis
3. Pyrolysis/Gasification
4. Pyrolysis/Steam Reforming
5. Conventional Gasification – Fluid Bed
6. Conventional Gasification – Fixed Bed
7. Plasma Arc Gasification
8. Anaerobic Digestion
9. Aerobic Digestion/Composting
10. Thermal Depolymerization

3.0 SUPPLIER SCREENING AND SUPPLIER TECHNOLOGY SUMMARY

About 225 suppliers were screened, and twenty-six suppliers were selected to submit their detailed qualifications to the City. In order to screen the technology suppliers, they were sent a brief survey based upon the technology screening criteria. The criteria were applied as follows:

- **Waste Treatability:** The supplier was screened on whether they have MSW or similar feedstock processing experience.
- **Conversion Performance:** The supplier was asked if their facility would produce marketable byproducts.

- **Throughput Requirement:** This criterion was already met because the technology passed the technology screen.
- **Commercial Status:** This criterion was already met because the technology passed the technology screen.
- **Technology Capability:** The supplier was asked if their technology had processed at least 25 tons/day of feedstock.

The suppliers that qualified to receive the Request for Qualifications are shown in Table 2.

**TABLE 2
TECHNOLOGY SUPPLIER SHORT LIST**

Technology Division	Technology	Supplier Name
Biological	Aerobic composting	Wright Environmental Management Inc. (Wright)
Biological	Aerobic composting	American Bio-Tech
Biological	Aerobic composting	Horstmann Recyclingtechnik GmbH
Biological	Anaerobic digestion	Canada Composting, Inc. (CCI)
Biological	Anaerobic digestion	Valorga S.A.S. (Valorga)
Biological	Anaerobic digestion	Organic Waste Systems N.V. (OWS)
Biological	Anaerobic digestion	ISKA GmbH
Biological	Anaerobic digestion	Arrow Ecology Ltd. (Arrow)
Biological	Anaerobic digestion	Citec
Biological	Anaerobic digestion	Global Renewables/ISKA
Thermal	Thermal	Changing World Technologies (CWT)
Thermal	Gasification	Primenergy (RRA)
Thermal	Gasification	Omnifuel/Downstream Systems (Omni)
Thermal	Gasification	Whitten Group/Entech Renewable Energy System (Whitten)
Thermal	Gasification	Energy Products of Idaho (EPI)
Thermal	Gasification	Ebara
Thermal	Destructive Distillation	Pan American Resources (PAR)
Thermal	Advanced Thermal Recycling	Consutech Systems LLC
Thermal	Advanced Thermal Recycling	Seghers Keppel Technology, Inc. (Seghers)
Thermal	Advanced Thermal Recycling	Waste Recovery Seattle, Inc. (WRSI)
Thermal	Advanced Thermal Recycling	Basic Envirotech Inc.
Thermal	Advanced Thermal Recycling	Covanta Energy Corp. (Covanta)
Thermal	Pyrolysis/Steam Reforming	Brightstar Environmental
Thermal	Pyrolysis	WasteGen Ltd./TechTrade (WasteGen)
Thermal	Pyrolysis	Taylor Recycling Facility, LLC/FERCO (Taylor)
Thermal	Pyrolysis/Gasification	Interstate Waste Technologies/Thermoselect (IWT)

Of the twenty-six suppliers requested to submit qualifications, seventeen provided responses. These suppliers and their technologies were thoroughly evaluated (including several site visits). This evaluation primarily was based upon the information and data contained in the submittals received. These submittals ranged from very responsive to incomplete. Each supplier was requested to provide additional information based on an initial review. Tables 3 through 5 provide a summary of the information obtained from each supplier.

4.0 LIFE CYCLE ANALYSIS

The supplier data were used to prepare a life cycle analysis associated with implementation of alternative waste processing technologies in the City’s integrated solid waste management system. This allows the City of Los Angeles to more accurately compare these new technologies to existing solid waste management practices. In a life cycle analysis, the energy and emissions associated with fuels, electrical energy, and material inputs for all stages of the waste management process (e.g., collection, transfer, treatment, disposal) also are captured. Similarly, the potential benefits of the process associated with energy and/or materials recovery displacing (avoiding) energy and/or materials production from virgin resources are captured. This process is depicted in Figure 2.

**FIGURE 2
LIFE CYCLE INPUTS AND OUTPUTS OF A
WASTE MANAGEMENT PROCESS**

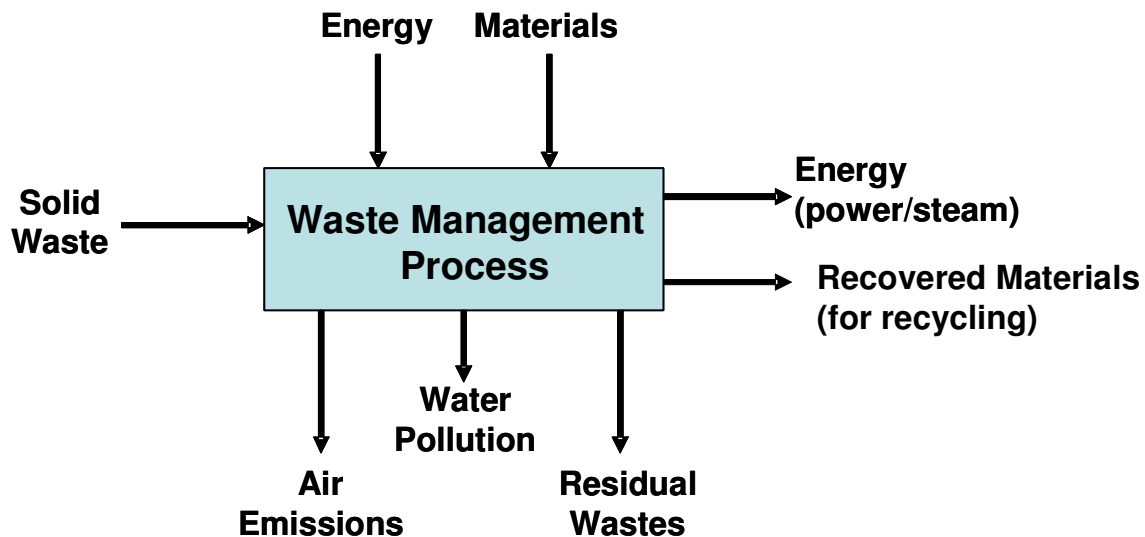

For this study, life cycle environmental profiles were developed for four alternative integrated MSW management scenarios for the current black bin post-source separated MSW in Los Angeles:

**TABLE 3
THERMAL CONVERSION FACILITIES**

	<i>Company Name</i>	Ebara	Interstate Waste Technologies (IWT)	Omnifuel (Omni)	Primenergy (RRA)
Company	<i>Headquarters</i>	Tokyo, Japan	Malvern, PA	Citrus Heights, CA	Stanton, CA
Biography	<i>Operating Plants (MSW/Other)</i>	12	3 ²	0/4	1/6
Technology	<i>Type</i>	Fluid Bed Gasification	Pyrolysis/Gasification	Fluid Bed Gasification	Fixed Bed Gasification
	<i>Technical Description</i>	TwinRec (Twin Internally Circulating Fluidized Bed Gasification) w/Ash Melting	Thermoselect High Temperature Gasification	Downstream Systems Hearst Gasifier	PRM Energy Gasification
Pre-Processing	<i>Description</i>	Shredders	Compaction, Degasing	MRF makes RDF	MRF makes RDF
	<i>MSW Delivered (TPY)</i>	100,000	100,000/370,000	100,000	360,000
	<i>Recovers Recyclables (Yes/No)</i>	No	No	Yes	Yes
Post Processing/ Byproducts	<i>Products</i>	Syngas	Syngas	Syngas	Syngas
	<i>Residue (tons/yr)</i>	11,365 (slag) 1,230 (metals)	15,000 (slag) 2,563 (metals)	2,600 (hot cyclone ash) 12,677 (rejects)	22,392 (bottom ash) 52,704 (rejects)
	<i>Diversion Rate</i>	91%	99%/99%	85%	85%
	<i>Worst Case Diversion Rate¹</i>	79%	81%/81%	85%	77%
Fuel Production Power Generation	<i>Type</i>	Boiler/Steam Turbine	Reciprocating Engine	Boiler/Steam Turbine	Boiler/Steam Turbine
	<i>Quantity (net MW)</i>	5.5	11/38	4.4	15
	<i>Efficiency (kWh/ton)</i>	376	838/875	459	600
	<i>Stack/Building/Tank Height (feet)</i>	N/A	< 50 ³	200 ³	100
Evaluated Economics	<i>Capital Costs (\$/ton)</i>	730	900/700	157	137
	<i>Annual O&M (\$millions)</i>	8.6	10.0/20.3	2.6	5.1
	<i>Electricity Revenues (\$million)</i>	2.3	5.0/19.9	1.6	7.8
	<i>Recoverable Revenues (\$million)</i>	0.12	0.55/1.6	1.3	4.6
	<i>Total Revenues (\$millions)</i>	2.4	5.6/21.5	2.9	12.4
	<i>Worst Case Break Even Tipping Fee (\$/ton)</i>	128	119/40	40	20

TABLE 3 (CONTINUED)
THERMAL CONVERSION FACILITIES

	<i>Company Name</i>	Taylor Recycling	WasteGen	Whitten	Pan American Resources (PAR)
Company	<i>Headquarters</i>	Montgomery, NY	Stroud, Glos. UK	Longview, WA	Pleasanton, CA
Biography	<i>Operating Plants(MSW/Other)</i>	0/5	2	5/41	0/5
Technology	<i>Type</i>	Circulating Fluid Bed Pyrolysis	Pyrolysis	Fixed Bed Gasification	Pyrolysis
	<i>Technical Description</i>	FERCO Silva Gas	Tech Trade Pyrolysis	Entech Renewable Energy System	Lantz Converter
Pre-Processing	<i>Description</i>	MRF makes RDF	Shredder	N/A	Sorting, Shredding, Drying
	<i>MSW Delivered (TPY)</i>	195,750	100,000	100,000/400,000	182,500
	<i>Recovers Recyclables (Yes/No)</i>	Yes	Yes	Yes	Yes
Post Processing/ Byproducts	<i>Products</i>	Syngas	Syngas	Syngas	Syngas
	<i>Residue (TPY)</i>	11,745 (hot cyclone ash)	20,000 (bottom ash) 2,241 (inerts)	4,195 (bottom ash) 5,801 (inerts)	38,143 (char, ash) 8,651 (rejects)
	<i>Diversion Rate (%)</i>	99%	99%	98%/98%	74%
	<i>Worst Case Diversion Rate (%)¹</i>	87%	79%	89%/89%	74%
Fuel Production	<i>Type</i>	Boiler/Steam Turbine	Boiler/Steam Turbine	Boiler/Steam Turbine	Boiler/Steam Turbine
Power Generation	<i>Quantity (net MW)</i>	12	9	7/28	6.5
	<i>Efficiency (kWh/ton)</i>	728	675	686/725	463
	<i>Stack/Building/Tank Height (feet)</i>	110	195	75 ²	33
Evaluated Economics	<i>Capital Costs (\$/ton)</i>	547	606	560/450	163
	<i>Annual O&M (\$millions)</i>	14.3	4.6	3.1/N/A	2.4
	<i>Electricity Revenues (\$millions)</i>	5.1	4.1	3.4/N/A	3.4
	<i>Recoverable Revenues (\$million)</i>	2.5	0.16	1.3/N/A	0.20
	<i>Total Revenues (\$millions)</i>	9.6	4.2	4.6/19.2	3.6
	<i>Worst Case Break Even Tipping Fee (\$/ton)</i>	67	55	44/38	16

¹ Calculated by normalizing recyclables to 16,500 tons/year and assuming all residuals, compost, or RDF is landfilled.

² 5 additional plants in development.

³ Assumed.

TABLE 4
ADVANCED THERMAL CONVERSION FACILITIES

	<i>Company Name</i>	Covanta	Waste Recovery Seattle Inc. (WRSI)	Seghers Keppel
Company	<i>Headquarters</i>	Fairfield, NJ	Newcastle, WA	Marietta, GA
Biography	<i>Operating Plants(MSW)</i>	25	1	12
Technology	<i>Type</i>	Thermal Recycling	Thermal Recycling	Thermal Recycling
	<i>Technical Description</i>	Martin GmbH	Rugenberger Damm GmbH	DANOdrum/ Water-cooled Grate
Pre-Processing	<i>Description</i>	None	None	Sorting and Magnetic Eddy Current, DANOdrum
	<i>MSW Delivered (TPY)</i>	329,000	380,000	368,000
	<i>Recovers Recyclables (Yes/No)</i>	No	No	Yes
Combustion Unit/ Byproducts	<i>Products</i>	Metals, Electricity	Bottom Ash, HCl, Gypsum, Electricity	Bottom Ash, Boiler Ash, Flue Gas Residue, Electricity
	<i>Combustion Residual (TPY)</i>	N/A	76,000 (bottom ash)	N/A
	<i>Diversion Rate (%)</i>	80%	98%	92%
	<i>Worst Case Diversion Rate (%)¹</i>	80%	78%	43%
Fuel Production	<i>Type</i>	Steam Turbine	Steam Turbine	Steam Turbine
Power Generation	<i>Quantity (net MW)</i>	23	25	19
	<i>Efficiency (kWh/ton)</i>	550	521	647
	<i>Stack/Building/Tank Height (feet)</i>	275	250	250 ²
Evaluated Economics	<i>Capital Costs (\$/ton)</i>	N/A	474	486
	<i>Annual O&M (\$millions)</i>	10.0	14.7	15.0
	<i>Electricity Revenues (\$millions)</i>	10.9	11.9	10.6
	<i>Recoverable Revenues (\$millions)</i>	0.8	2.1	1.7
	<i>Total Revenues (\$millions)</i>	11.7	14.0	12.3
	<i>Worst Case Break Even Tipping Fee (\$/ton)</i>	56	59	64

¹ Calculated by normalizing recyclables to 16,500 tons/year and assuming all residuals, compost, or RDF is landfilled.

² Assumed.

**TABLE 5
BIOLOGICAL CONVERSION FACILITIES**

	<i>Company Name</i>	Arrow Ecology	Canada Composting (CCI)	Global Renewables	Organic Waste Systems (OWS)	Wright Environmental (RDF only)	Waste Recovery Systems Inc. (Valorga)
Company Biography	<i>Headquarters</i>	Wheeling, WV	Newmarket, ON, Canada	Perth, Australia	Gent, Belgium	Richmond Hill, ON, Canada	Monarch Beach, CA
	<i>Operating Plants (MSW/Other)</i>	1	3/23	1	4/5	2/4	6/5
Technology	<i>Type</i>	Anaerobic Digestion	Anaerobic Digestion	Anaerobic Digestion	Anaerobic Digestion	Aerobic Composting (Biodryer)	Anaerobic Digestion
	<i>Technical Description</i>	The ArrowBio Process	BTA Process	ISKA, SCT	DRANCO	In-Vessel	Valorga
Pre-Processing	<i>Description</i>	Separation, Bag Breaking, Trommel	Sorting, Trommel, BTA pulper, Degritting	Mechanical separation	Separation, Hammer Mill	Sorting, Trommel, Shredding	Bag Breaking, Shredding, Sieve
	<i>MSW Delivered (TPY)</i>	100,000	100,000/300,000	100,000	100,000/300,000	100,000	100,000/300,000
	<i>Recovers Recyclables (Yes/No)</i>	Yes	Yes	Yes	Yes	Yes	Yes
	<i>Products</i>	Biogas	Biogas	Biogas	Biogas	RDF	Biogas
Post Processing/ Byproducts	<i>Compost (TPY) based on 100K MSW throughput</i>	23,000	22,000	21,000	40,000	44,000	20,000
	<i>Residue (TPY) based on 100K MSW throughput</i>	19,000	26,000	16,000	39,000	21,000	21,000
	<i>Diversion Rate</i>	81%	74%/74%	84%	61%/61%	78%	79%/79%
	<i>Worst Case Diversion Rate¹</i>	59%	64%/64%	N/A	33%/33%	42%	55%/55%
Fuel Production Power Generation	<i>Type</i>	Reciprocating Engine	Reciprocating Engine	Reciprocating Engine	Reciprocating Engine	RDF Pelletized Fuel	Reciprocating Engine
	<i>Quantity (net MW)</i>	2.6	0.9/1.33	0.9	1.4/4.1	5.4	1.5/4.6
	<i>Efficiency (kWh/ton)</i>	268	155/155	N/A	116/116	N/A	138/138
	<i>Stack/Building/Tank Height (feet)</i>	50 ²	70	26	65	< 50 ²	96

**TABLE 5 (CONTINUED)
BIOLOGICAL CONVERSION FACILITIES**

	<i>Company Name</i>	Arrow Ecology	Canada Composting (CCI)	Global Renewables	Organic Waste Systems (OWS)	Wright Environmental (RDF only)	Waste Recovery Systems Inc. (Valorga)
Evaluated	<i>Capital Costs (\$/ton)</i>	270	550/275	N/A	401/294	313	334/217
Economics	<i>Annual O&M (\$millions)</i>	1.2	7.05/N/A	N/A	4.8/N/A	3.57	3.02/N/A
	<i>Electricity Revenues (\$millions)</i>	1.4	0.61/N/A	N/A	0.73/N/A	N/A	0.81/N/A
	<i>Recoverable Revenues (\$millions)</i>	1.3	1.3/N/A	N/A	1.25/N/A	1.25	1.3/N/A
	<i>Total Revenues (\$millions)</i>	2.8	2.1/6	N/A	2.4/7.2	2.8	2.3/6.6
	<i>Worst Case Break Even Tipping Fee (\$/ton)</i>	19	97/61	N/A	62/45	51	42/23

¹ Calculated by normalizing recyclables to 16,500 tons/year and assuming all residuals, compost, or RDF is landfilled.

² Assumed.

- 1) Collection, transfer, and disposal in a conventional landfill, with landfill gas collection for the generation of electricity
- 2) Collection and transfer of the post-source separated MSW to and combustion in a thermal recycling facility to generate electricity with recovery of metals from the bottom ash and disposal of the bottom ash in a landfill
- 3) Collection and transfer of the post-source separated MSW to an alternative waste disposal facility, with gasification of the carbonaceous waste constituents and recovery of metal and glass and disposal of residuals in a conventional landfill
- 4) Collection and transfer of the post-source separated MSW to an alternative waste disposal facility, with anaerobic digestion of the biodegradable wastes, and recovery of metal and glass with disposal of residuals in a landfill

The analysis was conducted using RTI International's Municipal Solid Waste Decision Support Tool (MSW DST).

The following assumptions were applied to the four scenarios evaluated:

- 1,000,000 tons of solid waste per year is managed under each scenario considered.
- The waste composition of the post-source separated MSW is based on characterization data prepared by Cascadia in 2000.

The life cycle study focused on the issues that demonstrate greatest differentiation between advanced thermal recycling or conversion technologies, and existing traditional solid waste management processes. These issues were:

- **Energy Consumption.** Energy is consumed by all waste management activities (e.g., collection, material recovery facilities [MRFs], transportation, treatment, disposal), as well as by the processes to produce energy and material inputs that are included in the life cycle inventory. Energy offsets can result from the production of fuels or electrical energy and from the recycling of materials.
- **NO_x Emissions.** NO_x emissions, a criteria pollutant, are largely the result of fuel combustion processes. NO_x emission offsets can result from the displacement of combustion activities, mainly fuels and electrical energy production.
- **SO_x Emissions.** SO_x emissions also a criteria pollutant, are largely the result of fuel combustion processes. Likewise, SO_x emission offsets can result from the displacement of combustion activities, mainly fuels and electrical energy production, as well as the use of lower sulfur-containing fuels.

- **Carbon Monoxide.** Carbon monoxide is a component of motor vehicle exhaust, which is the largest source of CO; other sources include industrial processes, and power production. CO contributes to the formation of smog.
- **Carbon Emissions.** Carbon emissions contribute to the greenhouse effect; thus, these emissions can lead to climate change and its associated impacts. Carbon emissions can result from the combustion of fossil fuels and the biodegradation of organic materials (for example, methane gas from landfills). Offsets of carbon emissions can result from the displacement of fossil fuels, materials recycling, and the diversion of organic wastes from landfills.

The results for each life cycle scenario analyzed are summarized in Figures 3 through 6. These results are presented as *net* life cycle totals for each scenario. Therefore, a positive value represents a net life cycle burden, whereas a negative value represents a net life cycle benefit, savings or avoidance. For example, a negative value for energy consumption in the advanced thermal recycling, anaerobic digestion, and conversion technology scenarios means that more energy is generated than consumed, Significant energy offsets are also created through the recovery and recycling of metals.

**FIGURE 3
LANDFILL SCENARIO ILLUSTRATION**

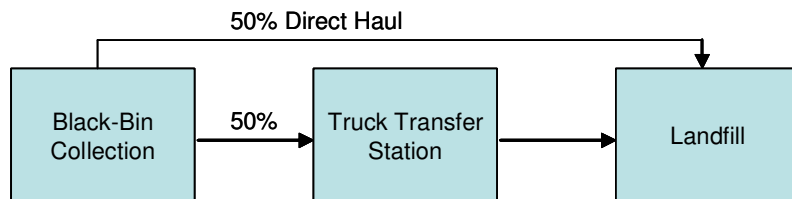

The process flow diagram shows only major process areas; for simplification, not all internal process streams are shown.

**FIGURE 4
ADVANCED THERMAL RECYCLING SCENARIO ILLUSTRATION**

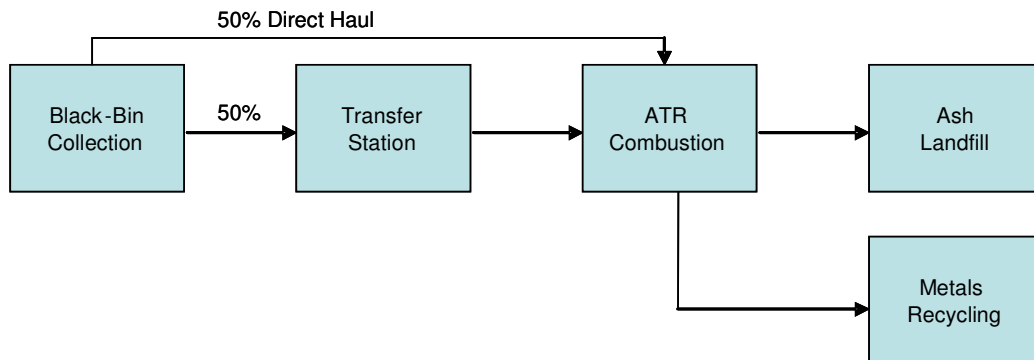

The process flow diagram shows only major process areas; for simplification, not all internal process streams are shown.

**FIGURE 5
PYROLYSIS/GASIFICATION SCENARIO ILLUSTRATION**

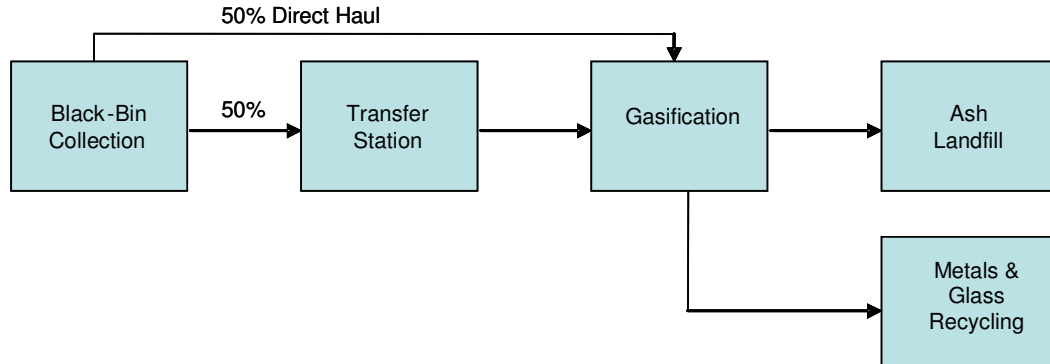

The process flow diagram shows only major process areas; for simplification, not all internal process streams are shown.

**FIGURE 6
WASTE CONVERSION (ANAEROBIC DIGESTION) SCENARIO**

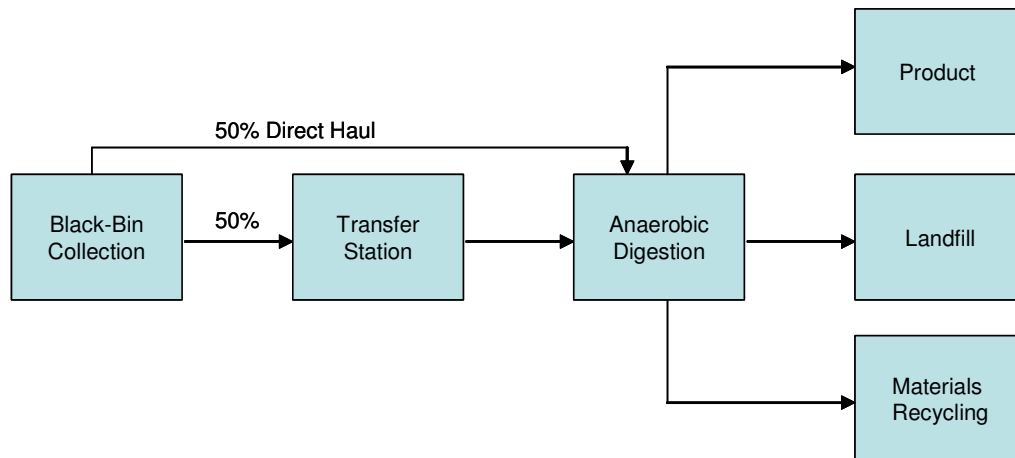

The process flow diagram shows only major process areas; for simplification, not all internal process streams are shown.

4.1 Net Energy Consumption

Energy, in the form of fuels and electricity, is directly consumed by all waste management activities (e.g., collection, transportation, treatment, disposal). Energy is also indirectly consumed in the production of energy and material inputs that are used by waste management activities. Both direct and indirect consumption of energy are included in the study.

As shown in Figure 7, the advanced thermal recycling and gasification scenarios for the City of Los Angeles result in large net energy savings. Anaerobic digestion also creates some energy savings, although only about half the savings from the thermal technologies.

**FIGURE 7
ANNUAL NET ENERGY CONSUMPTION BY SCENARIO**

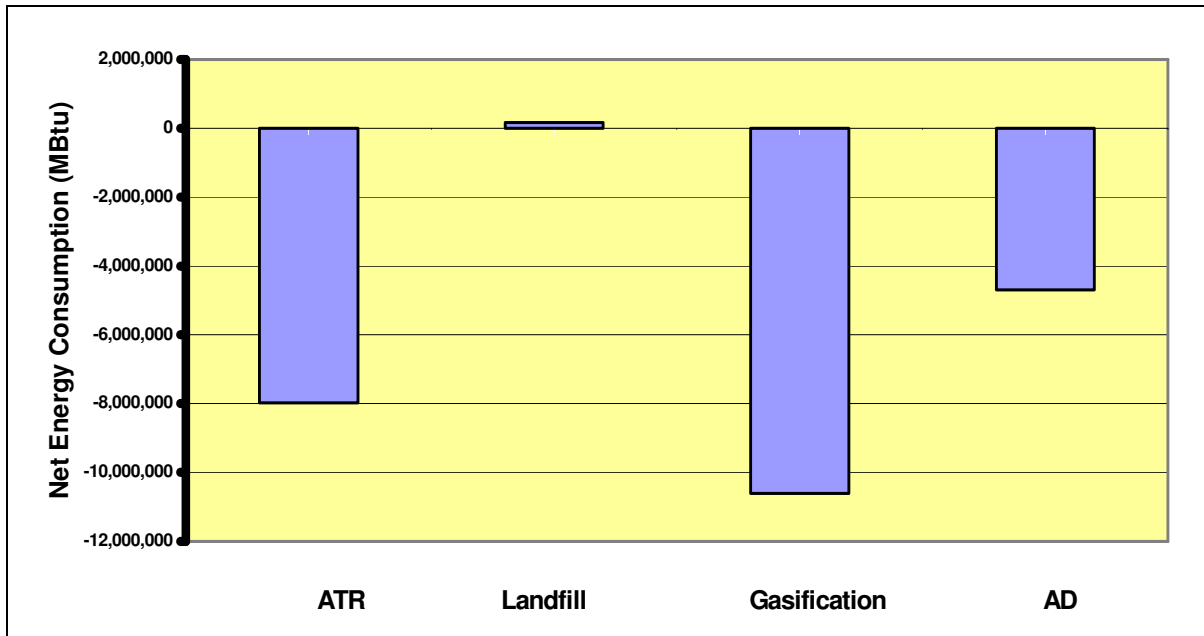

4.2 Criteria Pollutants

In general, emissions of criteria air emissions, including particulate matter, SO_x, NO_x, and CO, are lower (i.e., exhibit a savings) for the advanced thermal recycling, gasification, and anaerobic digestion scenarios than for the landfill scenario, as shown in Figure 8. This is largely due to the electrical energy and recycling offsets created by these technologies. The electrical energy offset in particular is highly correlated to criteria air emissions. The anaerobic digestion alternative performs about on par with advanced thermal recycling and gasification, except that it has higher net NO_x emissions.

4.3 Carbon Emissions

Carbon emissions contribute to the greenhouse effect. Carbon emissions result from the combustion of fossil fuels and the biodegradation of organic materials (e.g., methane gas from landfills). Offsets of carbon emissions can result from the displacement of fossil fuels, materials recycling, and the diversion of organic wastes from landfills. Carbon emissions are expressed in units of metric ton of carbon equivalent (MTCE), which is derived as follows:

$$[(\text{Fossil CO}_2 * 1 + \text{CH}_4 * 21) * 12 / 44] / 2000$$

FIGURE 8
ANNUAL NET POUNDS OF CRITERIA AIR EMISSIONS BY SCENARIO

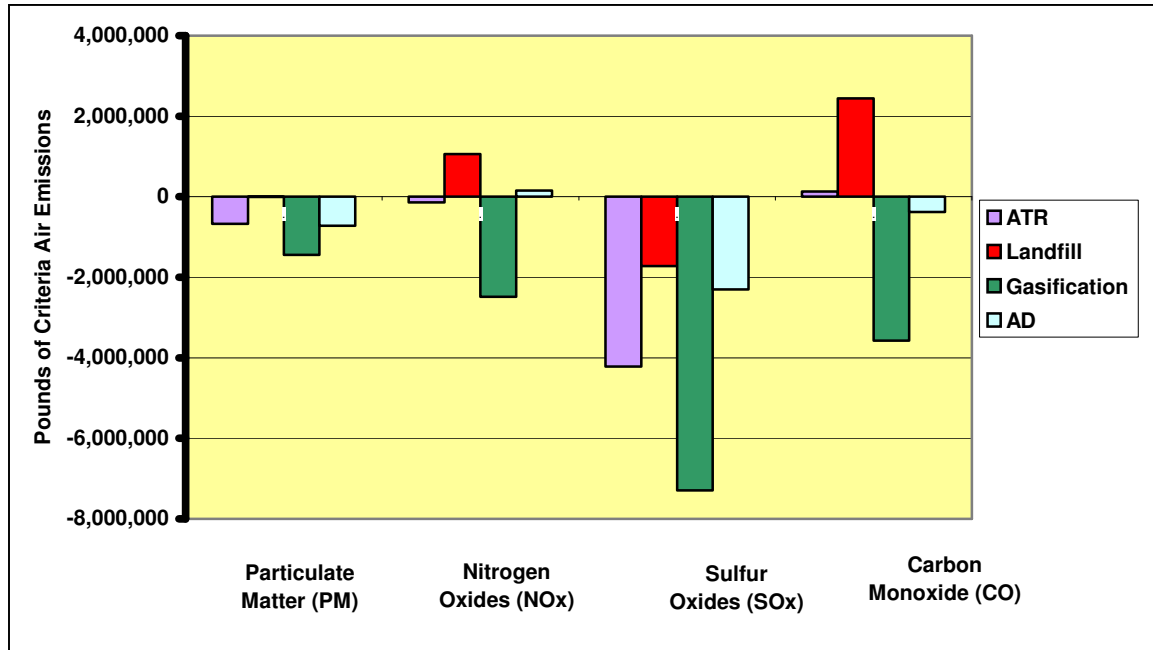

Note that methane has a 21x multiplier compared to CO₂ with regard to impact on greenhouse gas activity.

As shown in Figure 9, the advanced thermal recycling, gasification, and anaerobic digestion, scenarios exhibited net carbon emission savings.

The results of the life cycle analysis show that incorporating an alternative waste processing technology as part of the City's integrated waste management system would be an attractive option for black bin post-source separated MSW, from a life cycle environmental perspective. Each of the waste processing technologies evaluated (advanced thermal recycling, gasification, and anaerobic digestion) will provide substantial savings/reductions with respect to energy consumption, air emissions of criteria pollutants, and carbon emissions/climate change issues. This result is especially evident when comparing landfilling of post-source separated MSW versus treating this material in an advanced thermal waste processing facility.

5.0 COMPARATIVE ANALYSIS OF TECHNOLOGIES

Finally, the supplier data were used to conduct a comparative analysis of the technologies, and rank the suppliers to select technologies for further assessment. The comparative analysis addressed a number of technical, environmental, and cost issues, including:

FIGURE 9
ANNUAL NET METRIC TONS OF CARBON EQUIVALENT BY SCENARIO

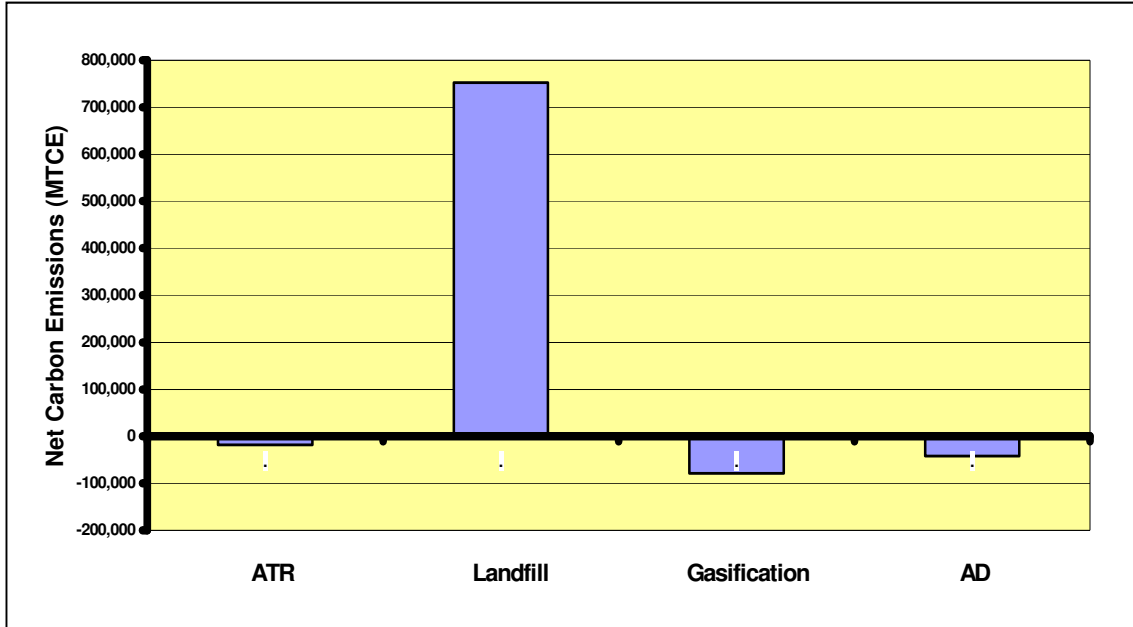

- Throughput (respondents provided data for different throughput rates)
- Electricity production
- Net efficiency in kWh/ton feedstock
- Diversion rate/solid wastes
- Air emissions
- Regulatory issues
- Capital cost
- Revenues
- Estimated tipping fees

Each of these comparisons is provided below.

5.1 Throughput

Data was requested from suppliers based upon a standard 100,000 TPY throughput, so that meaningful comparisons could be made. This throughput was selected for two reasons: it matched one-half the size of individual waste sheds in Los Angeles, and it was a size judged achievable by all suppliers based upon their prior experience. It should be noted that a design throughput for the proposed facility has not yet been selected.

However, this throughput was not a good match for some suppliers, particularly the advanced thermal recycling suppliers. Therefore, some responses included designs that better matched their module (equipment) sizing. The responses primarily fell into one of two categories: 100,000 TPY or 300,000-400,000 TPY.

Figure 10 shows the design throughputs evaluated in this study. The numbers after the suppliers in the figures represent the throughput in hundreds of thousands of tons per year.

**FIGURE 10
THROUGHPUT BY SUPPLIER (TPY)**

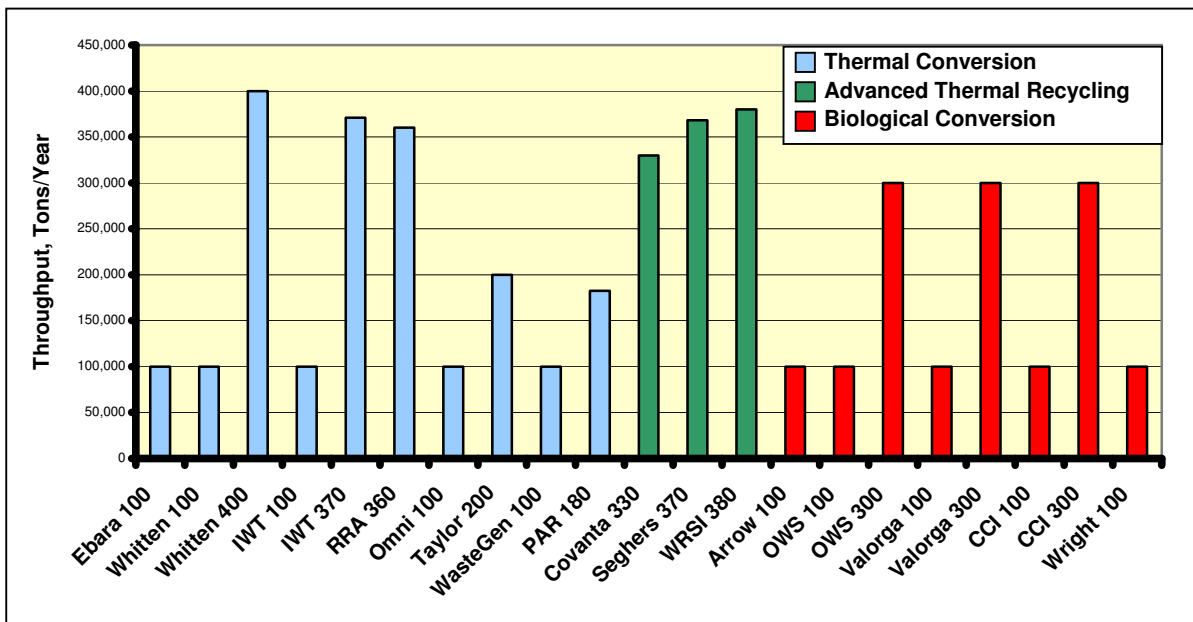

5.2 Electricity Production

Net MW (generation) is the amount of electricity that is available for sale on the grid, taking into consideration the amount of internal use by the facility (i.e., net = gross - internal use).

The net electricity production by supplier is shown in Figure 11. As noted above, electricity production within technology groups varies widely, mainly due to differences in throughput, choice of power generation equipment, and production of compost by biological conversion technologies.

The electricity production expressed as thermal efficiency (net kWh/ton feedstock) is shown in Figure 12. This shows the amount of net electricity generation per ton of feedstock processed in the conversion or combustion unit.

FIGURE 11
NET ELECTRICITY PRODUCTION, MW

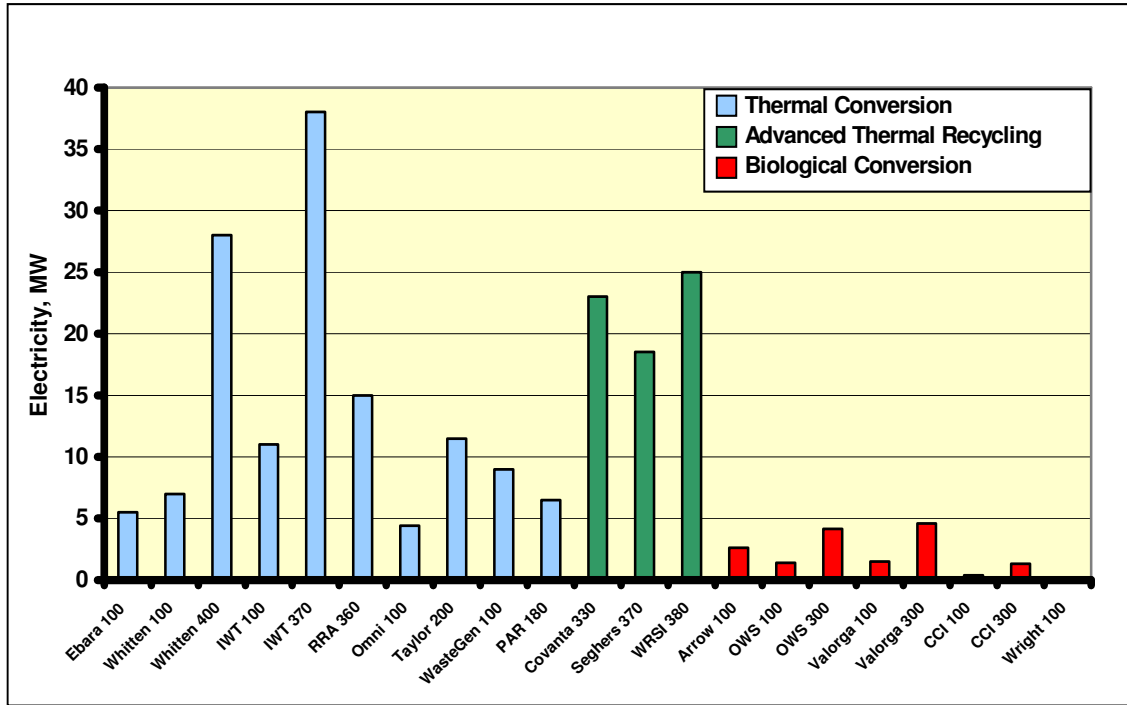
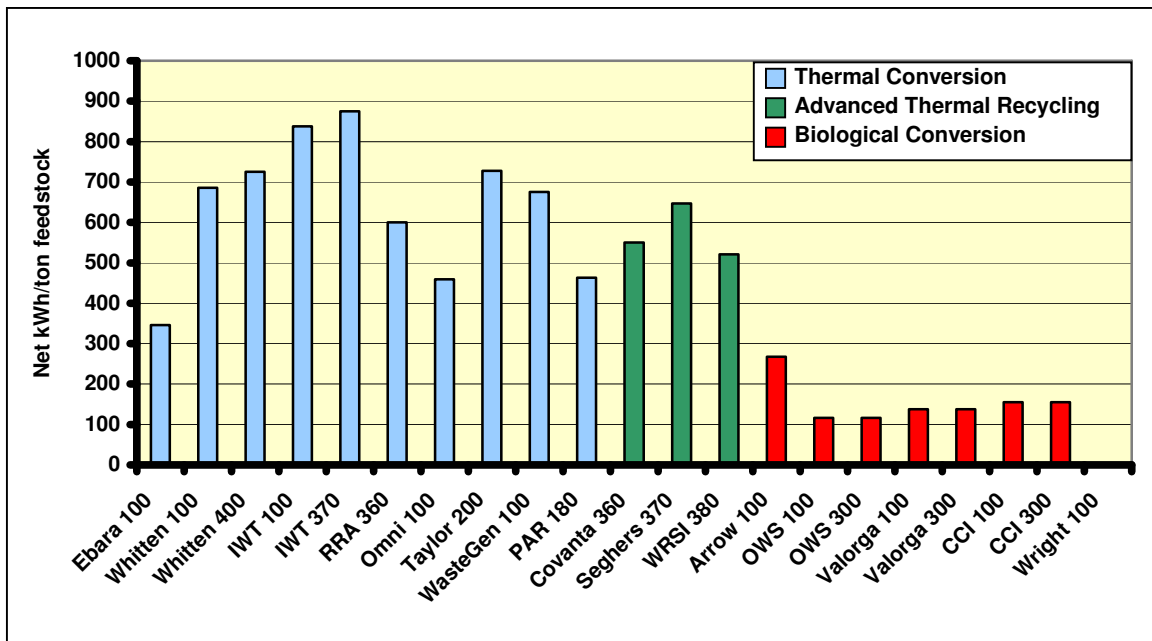

FIGURE 12
ENERGY EFFICIENCY, NET kWh/TON



- A higher quality feedstock, i.e., one with lower moisture and with non-convertible components with glass and metal removed, generally results in higher facility efficiency.
- Higher throughput generally results in higher efficiency.
- At these sizes, reciprocating engines are a more efficient method of power generation than conventional steam turbine generators. Typically, reciprocating engines will have efficiencies of about 40%, as compared to about 25% for small boilers.
- Converting more feedstock into energy is more efficient than producing large quantities of compost.

5.3 Diversion Rate

Diversion rate, measured in percent of total throughput, represents the amount of black bin post-source separated MSW that is recovered in pre-processing, processed in the facility, and recovered in post-processing, leaving unmarketable or unusable residues that must still be landfilled. This rate can vary depending upon the marketability of the solid materials produced. Bottom ash and compost materials will be marketable only if they meet regulatory standards in California.

If no agreement can be reached to use this material as alternative daily cover, some of this byproduct may require disposal as refuse in an appropriate landfill. Therefore, *as a theoretical worst case*, all solid byproducts would be sent to a landfill for disposal. This is mentioned here to illustrate the potential magnitude of the residue disposal problem should byproducts prove unmarketable.

Figure 13 shows the estimated diversion rate, and the worst-case diversion rate for each supplier. This graph illustrates that the thermal technologies will provide significantly higher diversion rates than biological technologies.

5.4 Air Emissions

Air emission levels and constituents of concern are a function of the specific designs of each technology, as well as the design of emission control systems. Therefore, this discussion will be limited to the three designated technology groups.

5.5 Advanced Thermal Recycling

These facilities meet all applicable regulatory limits on air emissions, including criteria pollutants such as NO_x and trace constituents such as dioxins, furans and metals. Concentrations of dioxins and furans are below detection limits. Similar, or lower, emissions would be expected from the advanced thermal recycling designs evaluated in this report, as they incorporate state-of-the-art emission control systems.

FIGURE 13
DIVERSION RATE, PERCENT OF THROUGHPUT

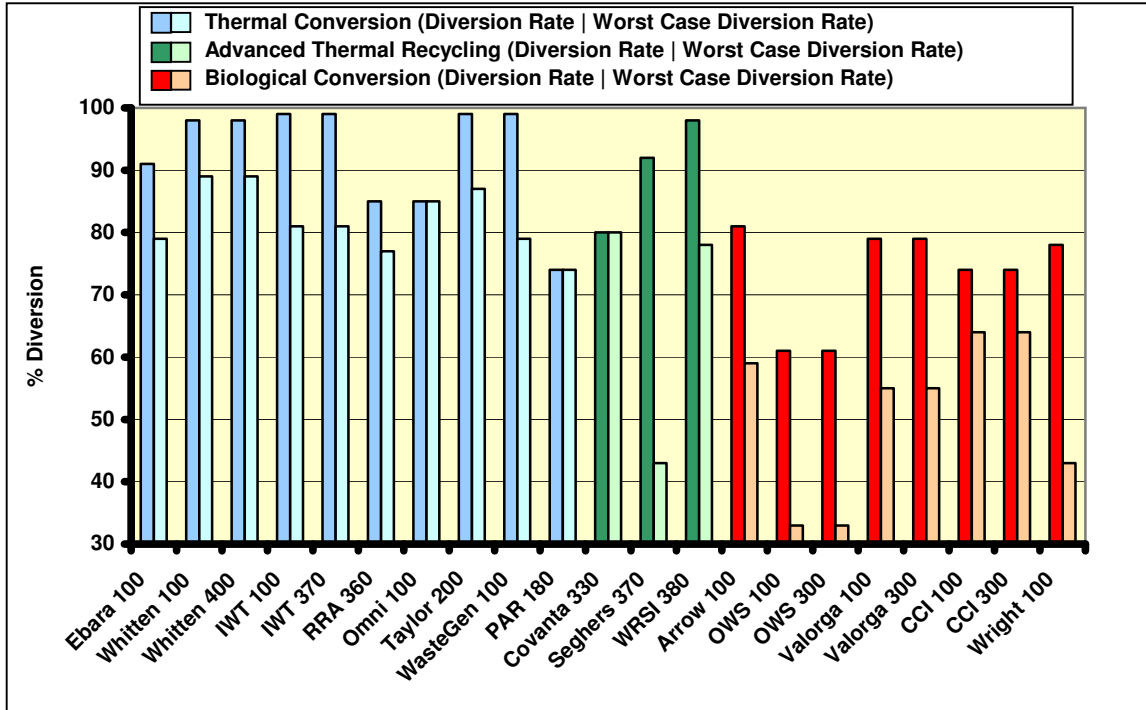

Advanced thermal recycling facilities are equipped with state-of-the-art air emission control systems designed to capture and recover components in the flue gas, converting them to marketable byproducts such as gypsum (for manufacturing wallboard) and hydrochloric acid (a chemical feedstock that can be used for water treatment).

The advanced thermal recycling emission control systems with recovery/recycling go beyond the technology utilized at existing resource recovery plants such as the Commerce Refuse-to-Energy Facility and the Southeast Resource Recovery Facility.

5.6 Thermal Conversion

At this early stage, without a detailed facility design, it was decided to address air emissions associated with thermal conversion in terms of their technical design issues as contrasted with advanced thermal recycling systems.

Thermal conversion technologies are much different than advanced thermal recycling facilities in terms of their design; therefore, air emissions characteristics will differ as well. Key design differences include:

- Thermal conversion processes occur in a reducing environment, typically using indirect heat without available air or oxygen, or with a limited amount of air or oxygen. With this

technology the formation of unwanted organic compounds or trace constituents is precluded or minimized.

- Thermal conversion technologies typically are closed, pressurized systems, so that there are no direct air emission points. Contaminants are removed from the syngas and/or from the flue gases prior to being exhausted from a stack.
- Thermal conversion technologies often incorporate pre-processing subsystems in order to produce a more homogeneous feedstock. This provides the opportunity to recover chlorine-containing plastic (as a recyclable), which could otherwise contribute to the formation of organic compounds and/or trace constituents.
- The volume of syngas produced in the conversion of the feedstock is considerably lower than the volume of flue gases formed in the combustion of MSW in an advanced thermal recycling facility. Smaller gas volumes are easier and less costly to treat.
- Pre-cleaning of syngas is possible prior to combustion in a boiler and is required when producing chemicals or prior to combustion in a reciprocating engine or gas turbine in order to reduce the potential for corrosion in this sensitive equipment. Syngas pre-cleaning also serves to reduce overall air emissions.
- Syngas produced by thermal conversion technologies is a much more homogeneous and cleaner-burning fuel than MSW.

As a result of these design differences, expected concentrations of criteria pollutants and trace constituents, including dioxins and furans, are expected to be, in general, lower than concentrations associated with advanced thermal recycling facilities. Therefore, thermal conversion facilities would meet or exceed all regulatory limits for air emissions.

5.7 Biological Conversion

Biological conversion facilities, specifically anaerobic digestion facilities, have several potential air emission pathways:

- Waste delivery and preprocessing: the emissions from these operations are approximately the same for all technologies and are adequately controlled by enclosing the operations inside a negative pressure-controlled building.
- Anaerobic digestion requires an airtight system, which precludes any air emissions from this step.
- Digestate processing/composting: could have significant air emissions, which are controlled by composting either in-vessel or inside a negative pressure-controlled building.

- Biogas combustion has emissions similar to those of any natural gas combustion process, which can be controlled to meet any air quality regulations.

Emissions per ton of MSW for biological conversion are inherently lower than those of MSW combustion or thermal conversion since biogas production and combustion is cleaner (conversion temperature is well below 200°F, and biogas combustion is similar to combusting natural gas). As a result, biological conversion of MSW is not expected to have significant air emissions concerns.

5.8 Regulatory Issues

Permitting an alternative MSW processing technology will require compliance with a variety of federal, California, County, and local environmental regulations. Each technology group will face different challenges.

5.9 Advanced Thermal Recycling

Advanced thermal recycling systems have a clearly established regulatory precedent, in that several resource recovery facilities have already been permitted in California. The last facility was permitted nearly fifteen years ago. The air quality related permitting will be complex; many new regulations have been promulgated since the early 1990s. Of particular import are the New Source Review, New Source Performance Standards (NSPS), and toxics.

Basic requirements of the New Source Review process include:

- Best Available Control Technology (BACT) analysis demonstrating that the proposed facility conforms to the South Coast Air Quality Management District's (SCAQMD) BACT Guidelines (there are established BACT guidelines for municipal waste combustion)
- Demonstration of compliance with all applicable State and Federal ambient air quality standards by performing air dispersion modeling of the proposed facility impacts using SCAQMD-approved modeling procedures
- Providing offsetting emission reductions for proposed emission increases by surrendering previously banked emission reduction credit (ERC) certificates

The NSPSs regulate emissions of oxides of sulfur (SO_x), oxides of nitrogen (NO_x), carbon monoxide (CO), particulate matter (PM), hydrogen chloride (HCl), dioxins/furans, cadmium, lead, mercury, fugitive ash, and opacity. In addition, the NSPS specify preconstruction notification, planning, analysis and reporting requirements as well as operating practices, monitoring, record-keeping, and reporting requirements.

The SCAQMD will complete NSR for air toxics pursuant to Rule 1401. Under this regulation a proposed facility with potential emissions of air toxics above screening thresholds would be required to complete a screening level health risk assessment using SCAQMD-specified procedures.

5.10 Thermal Conversion

Thermal conversion facilities may face the most challenging regulatory hurdles. Current California regulations addressing conversion technologies are not clear and contain numerous inconsistencies. While the California Integrated Waste Management Board (CIWMB) recognizes this problem, agency personnel are uncertain when regulations that provide a clear regulatory path will be promulgated. Until then, obtaining permits for a thermal conversion system will be problematical.

New Source Review, NSPS, and air toxics regulations, as described above for advanced thermal recycling, will also pertain to thermal conversion facilities.

5.11 Biological Conversion

Bioconversion facilities also have a relatively clear regulatory path, in that anaerobic digestion and aerobic digestion facilities have already been permitted in California. These facilities, however, use quite different feedstocks, including various forms of biomass, such as green waste and biosolids. Perhaps the most important regulatory hurdle will be meeting the complex regulatory requirements for utilization of compost materials produced from the post-source separated MSW. While anaerobic digestion facilities in Europe generally produce compost that is acceptable for marketing, their feedstocks are usually source-separated biowaste. European feedstock may be different in composition than the black bin contents.

5.12 Capital Cost

Capital cost is a function of technology, design considerations, and throughput.

Capital cost as cost per ton of annual throughput is shown in Figure 14 (Covanta did not provide a capital cost). The economies of scale achieved at higher throughputs are evident.

5.13 Annual Revenues

Annual revenues generated by each technology and supplier varied significantly by design and throughput.

Figure 15 shows total revenues as a function of throughput. Total revenues are defined as the revenues recovered from the sale of all byproducts and electricity, per ton of post-source separated MSW throughput processed (estimated based upon levelized recovery quantities).

FIGURE 14
CAPITAL COST, \$/TPY

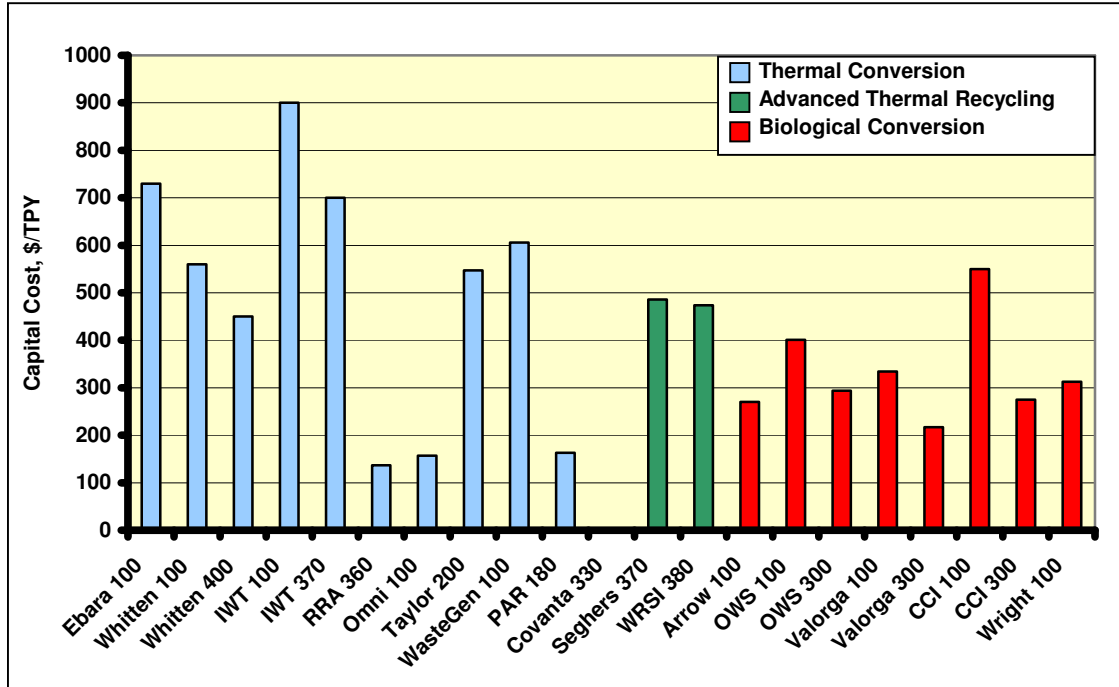
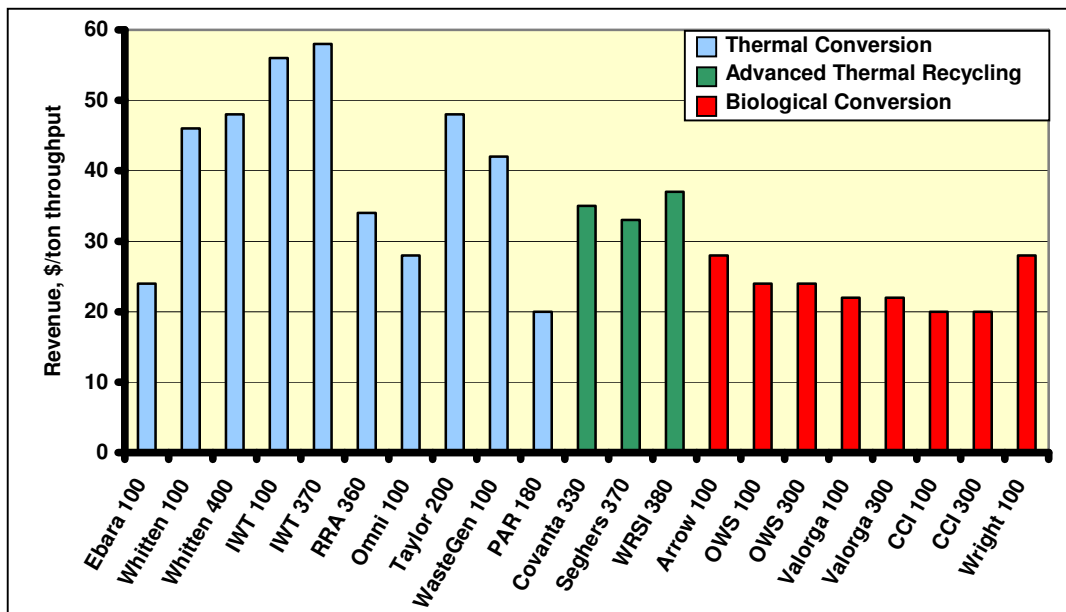

FIGURE 15
TOTAL REVENUE/TON BY SUPPLIER



The variability in Figure 15 primarily arises from these sources:

- Conversion to more electricity versus compost increases revenue/ton
- Pre-processing increases revenue/ton
- Higher efficiencies translate into higher revenues/ton

5.14 Breakeven Tipping Fees

Suppliers were asked to provide a tipping fee required to make their project economic. Although specific economic parameters were provided in the RFQ, suppliers calculated tipping fees using differing assumptions and different profit margins (where provided). To facilitate the evaluation, both a breakeven tipping fee and a worst-case breakeven tipping fee were calculated for each response. The breakeven tipping fee was estimated by adding capital recovery and interest charges to annual operating and maintenance costs and subtracting annual revenues calculated at standard prices using a fixed proportion of recyclables (16.5%) that would be recovered. The worst-case breakeven tipping fee was calculated by assuming that some byproducts, such as compost and bottom ash, would not be marketable, and would be transported to a landfill to be used as daily cover.

Figure 16 illustrates the estimated breakeven tipping fee and worst-case breakeven tipping fees for each submittal.

6.0 RANKING OF TECHNOLOGIES

Technologies were ranked using supplier data and the eight criteria shown in Table 6.

**TABLE 6
CRITERIA PERFORMANCE LEVELS AND RATINGS**

Criteria	Attributes
Ability to Market Byproducts	Experience selling byproducts with strong markets is desired
Visual Impact of Facility	Facilities with higher stacks or structures will exhibit greater visual impacts
Operational Experience	The number of operating plants is an indication of overall experience
Economics	Worst Case Breakeven Tipping Fee (WCBETF)
Supplier Credibility	Suppliers must have organizations (including partners) with sufficient technical and financial resources
Landfill Diversion	Percent by weight of inlet MSW sent to landfill (includes rejects and unmarketable materials – worst case)
Engineering the Complete System	Demonstrated ability to design the complete facility
Permitability	This is a function of expected environmental impacts, and the potential for a difficult regulatory process or pathway

FIGURE 16
ESTIMATED BREAKEVEN TIPPING FEE AND WORST CASE BREAKEVEN TIPPING FEE

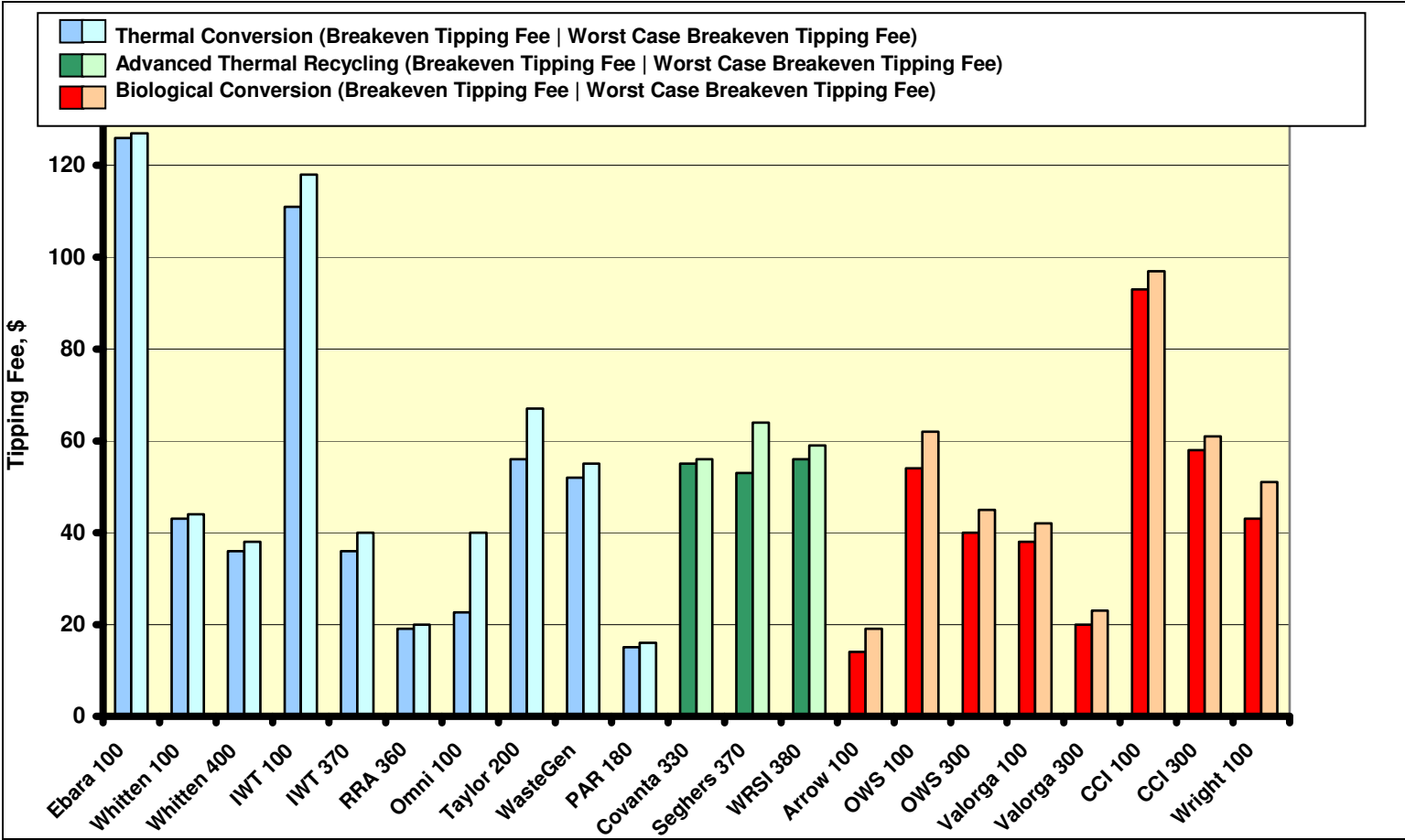

In summary, the ranking process, which is based upon the Bureau’s project objectives, indicates that thermal technologies (thermal conversion and advanced thermal recycling) are preferred alternative MSW processing technologies that will best satisfy the project’s highest level objective, i.e., maximize landfill diversion.

Figure 17 depicts the total ranking scores by Supplier.

**FIGURE 17
TOTAL RANKING SCORE BY SUPPLIER**

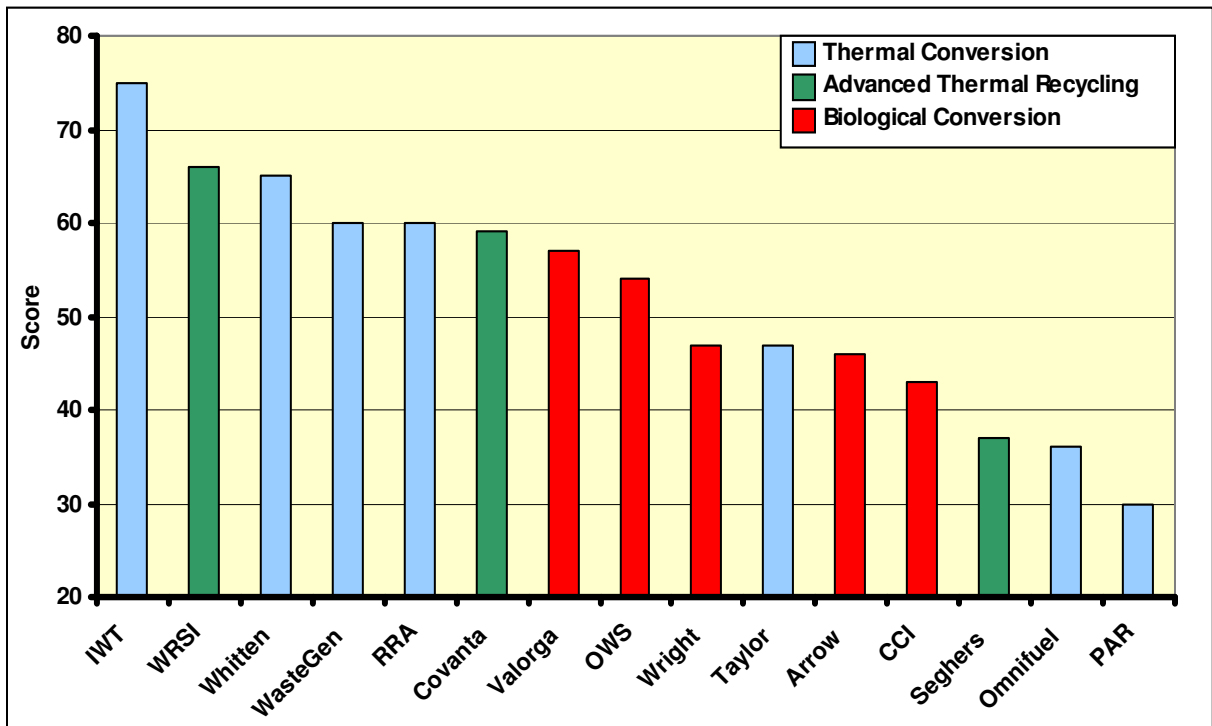

7.0 FINDINGS

The study evaluated the ability of alternative technologies to process black bin post-source separated MSW from three perspectives: siting (or environmental) feasibility, technical feasibility, and economic feasibility. The results of this evaluation, in part, can be expressed in terms of key findings that impact the overall study conclusions and recommendations that follow.

Table 7 provides a summary of these key findings. The table is arranged by objective (siting, technical, and economic), and each key finding is described, and discussed in the context of each technology evaluated. The study began with an evaluation of sixteen thermal, biological/chemical, and physical technologies, and these were screened on the basis of

**TABLE 7
KEY FINDINGS**

Key Finding Description	Advanced Thermal Recycling	Thermal Conversion	Biological Conversion
Siting/Environmental			
Diversion rate, the percentage of black bin post-source separated MSW that is diverted from landfilling, is an important objective for this project.	At least ninety percent diversion expected, with a worst-case rate of 80%.	At least ninety percent diversion expected, with a worst-case rate of 80%.	Eighty percent diversion rate expected with a worst-case rate of 50%.
Air emissions characteristics will differ among the alternative technology groups evaluated. All technology groups will meet regulatory limits.	Air emission control systems are available to limit emissions to well below regulatory limits.	Thermal conversion systems are expected to result in emissions well below regulatory limits.	Emissions from biological systems will be lower than thermal technologies due to lower operating temperatures.
Wastewater will be generated in relatively small quantities. This liquid waste will either be recycled or discharged to a local sewer.	No significant difference among technologies.		
Solid residue will be generated from material rejects, process waste, and air emission control systems.	Advanced thermal recycling systems will generate bottom ash, boiler ash, and fabric filter ash. Assuming the bottom ash is recycled, about 5% of the incoming material will be landfilled.	Similar to advanced recycling systems.	Biological systems will typically generate unmarketable residuals consisting of 15-40% of the total throughput.
An alternative MSW processing technology can be sited in urban Los Angeles.	No fatal siting constraints were identified. The best sites will be in heavy industrial (M3) areas of the City.	No fatal siting constraints were identified. The best sites will be in heavy industrial (M3) or heavily commercial areas of the City.	No fatal siting constraints were identified. The best sites will be in heavy industrial (M3) or heavily commercial areas of the City.
The pathway regarding environmental regulations differs by technology in California.	Several waste-to-energy facilities have been permitted in California. Therefore, regulations exist for advanced thermal recycling systems to obtain the required environmental permits to operate.	The legislature and the CIWMB are establishing a regulatory framework for thermal conversion technologies. The lack of such a framework will complicate permitting these facilities.	The technology for biological conversion in this study is anaerobic digestion. Regulations exist in California for this technology, although no systems have been permitted for treatment of MSW.

**TABLE 7 (CONTINUED)
KEY FINDINGS**

Key Finding Description	Advanced Thermal Recycling	Thermal Conversion	Biological Conversion
Life Cycle Analysis of energy consumption reveals advantages of employing thermal or biological MSW processing technologies.	Thermal technologies and biological conversion technologies will create significant energy savings when compared to landfilling. This energy savings results from a combination of syngas and electrical energy production, as well as from materials recovery and recycling. For example, if a 250,000 TPY per year thermal conversion facility replaced this quantity of black bin post-source separated MSW going to the landfill, the energy savings would be about 2.6 million MBtu, which is equivalent to a 30 MW power plant operating for one year.		
Life Cycle Analysis of criteria pollutant emissions reveals advantages of employing thermal or biological MSW processing technologies.	For the criteria air emissions, the advanced thermal recycling, gasification and anaerobic digestion scenarios also performed generally better than landfilling. The reduced transportation needed to take waste to the landfill contributed to the air emission reductions offered by advanced thermal recycling, gasification, and anaerobic digestion. For example, if a 250,000 TPY thermal conversion facility treated this quantity of black bin post-source separated MSW, about 425 tons of NO _x emissions per year would be saved (avoided), which is equivalent to the NO _x emissions emitted from a 975 MW natural gas-fired power plant operating for a year.		
Technical			
The technical maturity of alternative MSW processing technologies differs.	Combustion of MSW is the most mature of the alternative MSW processing technologies evaluated. Approximately 100 such facilities are operational in the U.S., with many more in Europe and Japan (these facilities are predecessors of the new advanced thermal recycling technology).	Thermal conversion technologies have been in successful, long-term use around the world, although typically using more homogeneous feedstocks such as coal and biomass. While technical challenges are expected, because of their relatively short operating history using MSW as a feedstock, these challenges are judged to be manageable.	Biological conversion facilities processing source separated organics (SSO), and more recently MSW, are operating in Europe and elsewhere overseas.
Facility designs are relatively new; therefore, current facility designs generally have not achieved the desired level of optimization.	There is room for improvement in most designs that would better integrate the three major components of a system (pre-processing, combustion/conversion, and post-processing/byproduct production). This would increase efficiency and reduced cost/ton.		
Air emission control systems are commercially available to limit air emissions to below regulatory levels for all technologies.	Applies to all technology groups.		

**TABLE 7 (CONTINUED)
KEY FINDINGS**

Key Finding Description	Advanced Thermal Recycling	Thermal Conversion	Biological Conversion
Thermal efficiency, the amount of net electricity generation per ton of feedstock processed, varies by technology. Higher efficiencies result in better financial performance.	Thermal technologies that use a steam turbine for electricity production have thermal efficiencies in the range of about 500-600 kWh/ton. If a reciprocating engine is used, the efficiency will increase to about 800-900 kWh/ton.		Thermal efficiency is in the range of 150-200 kWh/ton using reciprocating engines. Thermal processes recover more energy than biological ones because they convert essentially all organics to energy, not just the biodegradable organics.
Solid residuals generated by these technologies differ in composition.	Residuals include boiler and fabric filter fly ash (assumes bottom ash is recyclable). This material, although small in terms of quantity (about 7500 tons/yr for a 400,000 TPY facility), may be classified as hazardous.	Residuals for low temperature gasification and pyrolysis include boiler and fabric filter fly ash, and bottom ash (if not recycled). These materials, although small in quantity (1000-6000 tons/yr for a 100,000 TPY facility), may be classified as hazardous. Residuals (slag) from high temperature gasification will be non-hazardous and inert.	Residuals primarily will consist of unmarketable rejects, which will be landfilled. Quantities will range from 15,000 to 40,000 tons/yr for a 100,000 TPY facility.
Revenue/ton can be viewed as a measure of recycling effectiveness, or the ability of the technology to achieve higher market value for its byproducts.	Suppliers in this category can achieve revenues of about \$32-36 per ton.	Suppliers in this category can achieve revenues of up to \$40-60 per ton. This higher range is due to greater pre-processing and higher thermal efficiencies.	Suppliers in this category can achieve revenues of about \$20-30 per ton. This lower range is due to the production of compost.
The quality of response from the suppliers affected the results of this study with regard to the technical evaluation.	The quality of response from suppliers varied. Some responses were incomplete, and others indicated that some information and data were confidential. This situation affected the presentation of material in this report, particularly with respect to technical issues and economics.		
Economics			
The financial feasibility, as measured by a breakeven tipping fee, varied among technologies and suppliers.	Advanced thermal recycling systems exhibited breakeven tipping fees of \$56-\$64/ton for 330-380K TPY facilities. The small range is attributed to the extensive experience with this technology (i.e. its predecessor technology) in the U.S.	Thermal conversion breakeven tipping fees exhibited a wide range (\$20-\$128/ton for 100K TPY, and \$20-\$40/ton for 360-400K TPY facilities). This is attributed to the lack of experience with these facilities in the U.S.	Biological conversion breakeven tipping fees exhibited a wide range (\$19-\$97/ton for a 100K TPY facility).

**TABLE 7 (CONTINUED)
KEY FINDINGS**

Key Finding Description	Advanced Thermal Recycling	Thermal Conversion	Biological Conversion
Economy of scale is a term that refers to the variation in project economics with facility throughput. In general, the tipping fee decreased with increasing throughput.	Only one size was proposed (330-380K TPY)	Several responses addressed throughput levels from 100K to 400K TPY. In some cases, significant reductions in tipping fee result with higher throughputs, although insufficient data exists to be specific.	Several responses addressed throughput levels from 100K to 300K TPY. In some cases, significant reductions in tipping fee result with higher throughputs, although insufficient data exists to be specific.
Byproduct marketability is an important issue. Significant uncertainty with regard to some materials may impact economic viability.	Advanced thermal recycling gains most of its revenue from the sale of electricity. This is a well-developed market. Although only small amounts of bottom ash are presently recycled/reused, this is expected to increase as designs isolate the potentially hazardous fly ash from the bottom ash.	Thermal conversion gains most of its revenue from the sale of electricity, a well-developed market. Another significant revenue source for some designs are the recyclables recovered from pre-processing the inlet black bin post-source separated MSW. The market for glass, metals and paper is also well-developed.	Biological conversion facilities produce both electricity and compost. The compost is produced in large quantities (15,000-40,000 tons/yr for a 100K TPY facility). California compost quality regulations are complex. Extensive testing is required to ensure acceptability. In addition, the market for this material is uncertain.
With regard to conversion technologies, the relationship of project economics to supplier experience generally indicates that the more experienced suppliers provide higher project costs.		The lowest breakeven tipping fees (in the neighborhood of \$15-\$30/ton) were provided by suppliers with the least number of operating units. These results could not be verified in this study; therefore, additional evaluation is needed.	
Pre-processing to remove recoverable recyclables increases revenues. The value of uncontaminated recyclables in the black bin post-source separated MSW is higher as a recyclable material than as a feedstock to produce electricity.		Applies to all technology groups.	

ability and experience processing black bin post-source separated MSW on a commercial level to arrive at the following short list of technologies:

- Thermal technologies – Advanced thermal recycling, and thermal conversion (includes pyrolysis, gasification and pyrolysis-gasification)
- Biological/chemical – Anaerobic digestion
- Physical – None

As a result, the key findings address advanced thermal recycling, thermal conversion, and biological conversion.

Table 7 includes references to report sections where each finding is discussed in more detail.

8.0 CONCLUSIONS

Based upon the key findings, the following conclusions are made:

- An alternative MSW processing facility can be successfully developed in the City of Los Angeles.
- The technologies best suited for processing black bin post-source separated MSW on a commercial level are the thermal technologies. These include advanced thermal recycling and thermal conversion (pyrolysis and gasification).
- The biological/chemical conversion technologies and physical technologies present significant technical challenges for treatment of the black bin post-source separated MSW. While biological conversion technologies show the most promise in this group, they also bring significant challenges, as explained below.

The technology ranking evaluated the thermal and biological technologies using eight criteria that addressed siting, technical, and economic issues. While the ranking was conducted using supplier data, the results were used to decide which technology groups exhibited the best characteristics with regard to successfully processing of black bin post-source separated MSW.

Based upon the ranking scores in terms of technologies rather than suppliers, the following conclusions are drawn:

- Advanced thermal recycling and thermal conversion received the highest total scores.
- Advanced thermal recycling and thermal conversion received the highest environmental scores, primarily due to advantages with regard to landfill diversion rate.
- All three technologies were in the top five scores on engineering.

All three technologies received similar scores on economics, although advanced thermal recycling and thermal conversion ranked higher on byproduct marketability.

In summary, the advantages of the thermal technologies over biological conversion are:

- Higher landfill diversion rates, which is a primary objective of the project
- Lower production of solid byproducts and correspondingly greater production of electricity, a higher value product with a more well-developed and stable market
- Less risk with regard to byproduct marketability, particularly in comparison to compost
- Significantly higher thermal efficiencies and, therefore, higher revenue/ton because thermal processes convert essentially all organics (not just biodegradables) to energy
- More operational experience at higher throughputs

9.0 RECOMMENDATIONS

It is recommended that the City of Los Angeles proceed with the activities listed in Table 8 for continued development of an alternative MSW processing facility for black bin post-source separated MSW utilizing a thermal technology.

**TABLE 8
RECOMMENDED ACTIVITIES FOR MSW PROCESSING FACILITY
DEVELOPMENT FOR THE CITY OF LOS ANGELES**

Activity	Approximate Dates
Initiate Public Outreach	September 2005, ongoing
Develop Short List of Suppliers	September-November 2005
Conduct Initial Siting Study	September-November 2005
Prepare Request for Proposal (RFP)	November-February 200
Issue RFP	March 2006
RFP Responses Due	June 2006
Evaluate RFP Responses	June-October 2006
Announce Preferred Supplier(s)	October 2006
Conduct Facility Permitting/Conceptual Design	October 2006-October 2007
Prepare Detailed Facility Design	July 2007-December 2007
Facility Construction	January 2008-October 2009
Performance Testing and Start-up	October 2009-January 2010
Commercial Operation	(February 2010)

Each of the activities in Table 8 is discussed below.

9.1 Initiate Public Outreach

Public acceptability will be one of the most important determinants of this project's success. Siting, permitting and developing a new alternative MSW processing technology for the City of Los Angeles will lead to many questions from the public with regard to environmental impacts and public health issues. The key is to consider the public as a partner and present the facts and benefits as early as possible while being responsive to their concerns at all times. Developing early relationships with key stakeholder groups is essential.

The public outreach should be conducted in two phases. The first phase begins in the Fall of 2005, with two purposes: educate the public about the alternative MSW processing technologies, and elicit feedback regarding the public's attitude toward the technologies under consideration. Education about the characteristics of the technologies, compared to existing disposal methods, their benefits, and their anticipated environmental impacts are critical tasks. Public outreach is also important at this stage to provide counterpoint to opposing groups. A communications strategy in the first phase will access the public in broad terms, to reach large audiences, using techniques such as television spots, radio interviews, press conferences, and editorial pieces. Selected focus groups, as well as meetings with community leaders, agency personnel knowledgeable about emerging MSW processing technologies, and environmental groups also would be helpful.

The second phase of public outreach takes place after the technology supplier is selected and alternative site locations are known. Then the outreach becomes more specific than before, and is focused on the communities, which could be directly affected by the project. The communications strategy in this phase will use techniques that involve the affected communities, such as Citizen's Advisory Committees and specific neighborhood councils.

9.2 Develop a Short List of Suppliers

Prior to issuing a Request for Proposal (RFP) to select a supplier for the alternative MSW processing technology, a list of suppliers eligible for receiving this RFP will be developed.

This short list will be compiled using the following input:

- Results of the supplier evaluation conducted during this study.
- A review of the key uncertainties remaining after the supplier evaluation carried out in this study. Additional discussion with selected suppliers may be held to address issues such as methods to improve facility reliability and efficiency, ways to reduce design risks (use of standardized equipment where feasible), and further evaluation of costs and revenue projections.
- Feedback from the public outreach program scheduled to be initiated in the Fall of 2005 with regard to technology preferences.

9.3 Conduct Initial Siting Study

An RFP must be quite specific with regard to site characteristics in order to encourage the most detailed and complete responses. Potential bidders will want to know more information about site environmental constraints and availability of infrastructure. This information must be compiled while the RFP is being prepared.

9.4 Prepare a Request for Proposal and Select Preferred Suppliers

A technology supplier must formally be selected for this project. This will be accomplished by issuing an RFP to selected bidders. The RFP will contain a detailed set of instructions about how to reply, and will require the bidder to provide a comprehensive design along with a detailed cost and revenue estimate and information on performance guarantees and financing. The responses to the RFP will be evaluated, and a preferred supplier will be selected.

9.5 Conduct Facility Permitting and Conceptual Design

Once a technology supplier has been selected, a conceptual design is prepared to support preparation of required environmental and permit application documents. In parallel, these environmental documents will be prepared, and submitted to the appropriate agencies for processing. A series of public meetings will be held during agency review.

9.6 Perform Detailed Design and Construction

Finally, the detailed design is prepared, which will support facility construction, followed by construction, start-up, and initiation of operation. Commercial operation is targeted for mid-2010.